

ALUPROFIL

MM
mirotechmont

KOMPATIBILNÍ ŘADY PROFILŮ & SYSTEM-ENGINEERING

> KOMPATIBILNÍ ŘADY PROFILŮ
> SÉRIE KOMPATIBILNÍCH PROFILŮ

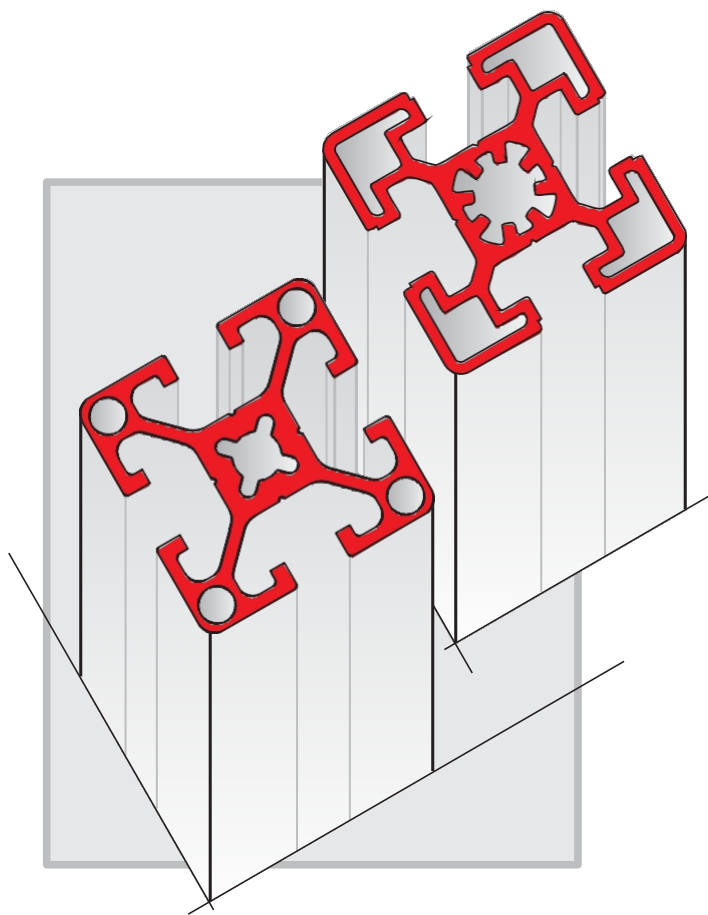

... A ZASE DOBŘE VYŘEŠENO! ...

ZNOVU DOBŘE VYŘEŠENO

... A ZNOVU DOBŘE VYŘEŠENO



„Pomocí konceptů pro štíhlou výrobu a intralogistiku pomáháme firmám dosáhnout maximálního úspěchu.“

> „Pomáháme firmám dosáhnout maximálního úspěchu pomocí konceptů štíhlé výroby a intralogistiky.“

> « Nous aidons les entreprises à atteindre un maximum de succès avec des concepts de production allégée et d'intralogistique. »

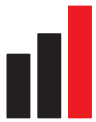

Efektivní technologie

- > Efektivní technologie
- > Účinná technologie

Řešení na míru

- > Řešení na míru
- > Řešení na míru

Vše z jedné ruky

- > Vše z jedné ruky
- > Vše z jednoho zdroje

Rozmanitost produktů

- > Rozmanitost produktů
- > Rozmanitost produktů

Hliníkový profilový systém

- > Hliníkový profilový systém
- > Systèmes de profilés d'aluminium



ECO-Rohrstecksystem

- > Systém spojek trubek ECO
- > Système de tubes ECO



Systém pracovišť

- > Systém pracovišť
- > Système de postes de travail



MySHADOWBOARD

- > MySHADOWBOARD
- > MySHADOWBOARD



Schutzzaunsystem

- > Ochranný plotový systém
- > Système de barrière de protection



Fördertechnik

- > Dopravní technika
- > Technique d'acheminement



Více informací na ...

- > Více informací na ...
- > Více informací na ...





POPIS SYSTÉMU	POPIS SYSTÉMU	ZÁKLADNÍ PRINCIP	1
ALU-PROFILE	PROFILY	PROFILY	2
SPOJOVACÍ PRVKY	SPOJOVACÍ PRVKY	SPOJOVACÍ PRVKY	3
ÚHLY / KLOUBY	KONZOLY / SPOJE	ÚHLÁKY / KLOUBY	4
PODLAHOVÉ PRVKY / NOHY / KOLEČKA	PODLAHOVÉ PRVKY / NOHY / KOLEČKA	NOŽKY / KOLEČKA	5
KRYTKY / PŘÍSLUŠENSTVÍ	KRYTKY / PŘÍSLUŠENSTVÍ	KRYTY / PŘÍSLUŠENSTVÍ	6
PLOCHOVÉ PRVKY	PANELOVÉ PRVKY	VÝPLNĚ	7
DVEŘE / DVEŘNÍ PRVKY	DVEŘE / PRVKY DVEŘÍ	DVEŘE A PŘÍSLUŠENSTVÍ	8
INSTALAČNÍ PRVKY	INSTALAČNÍ PRVKY	PNEUMATICKÉ / ELEKTRICKÉ	9
EKOLOGICKÝ TRUBKOVÝ SYSTÉM	EKOLOGICKÝ POTRUBNÍ SYSTÉM	ECO MECANO	10
OCHRANNÉ A ODDĚLOVACÍ SYSTÉMY	BEZPEČNOSTNÍ A ODDĚLUJÍCÍ SYSTÉMY	OCHRANNÉ PÁLICE	11
LINEÁRNÍ VODÍCÍ TECHNIKA	TECHNOLOGIE LINEÁRNÍHO VEDENÍ	TECHNIKA LINEÁRNÍHO VEDENÍ	12
FÖRDERSTRECKE N-ELEMENTE	PRVKY DOPRAVNÍKOVÝCH ÚSEKŮ	KONVOJE	13
NÁSTROJE A ZAŘÍZENÍ	NÁSTROJE A ZAŘÍZENÍ	NÁSTROJE A ŠABLONY	14
PŘEHLED OBJEDNÁVKOVÁ ČÍSLA	PŘEHLED OBJEDNÁVKOVÝCH ČÍSEL	INDEX	15

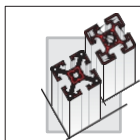

CESTA K SPRÁVNÉMU PROFILU ...

NAJÍT SPRÁVNÝ PROFIL ... POUR
TROUVER LE BON PROFILE ...



Profilová

řada

Série profilů · Série profilů

16 / 20 30 / 40 / 45 / 50

Pokračovat s velikostí profilu
Pokračovat s rozměrem profilu
Rozměr profilu

Pokračovat s provedením profilu
Pokračovat s provedením profilu
Provedení profilu

Profilové provedení

Profilový design

Verze profilu

	20	5	20	30	8E	30	30-10K
Hmotnost			0,48 kg/m			0,81 kg/m	1,00 kg/m
st			0,74 cm ⁴			2,78 cm ⁴	3,17 cm ⁴
I_x / I_y W_x / W_y			0,74 cm ³			1,85 cm ³	2,11 cm ³
od strany			■ 2,07			■ 2,13	■ 2,19

	40	8	40EL-1,4	40L-1,55	40-10000	40N	40MS	40S
Hmotnost			1,37 kg/m	1,55 kg/m	1,60 kg/m	1,72 kg/m	1,90 kg/m	2,45 kg/m
t			7,42 cm ⁴	8,40 cm ⁴	9,46 cm ⁴	9,66 cm ⁴	10,52 cm ⁴	13,90 cm ⁴
I_x / I_y W_x / W_y			3,71 cm ³	4,20 cm ³	4,73 cm ³	4,83 cm ³	5,26 cm ³	6,95 cm ³
od strany			■ 2,23	■ 2,23	■ 2,39	■ 2,29	■ 2,43	■ 2,47

	45	10	45EL-1,4	45L-1,6	45N-1,9	45MS-2.1	45S
Hmotnost			1,40 kg/m	1,60 kg/m	1,90 kg/m	2,10 kg/m	2,62 kg/m
t			9,28 cm ⁴	10,17 cm ⁴	12,95 cm ⁴	15,56 cm ⁴	18,95 cm ⁴
I_x / I_y W_x / W_y			4,12 cm ³	4,52 cm ³	5,18 cm ³	6,92 cm ³	8,42 cm ³
od strany			■ 2,55	■ 2,55	■ 2,61	■ 2,65	■ 2,65

Velikost

profilu

Rozměr profilu · Taille de profilé

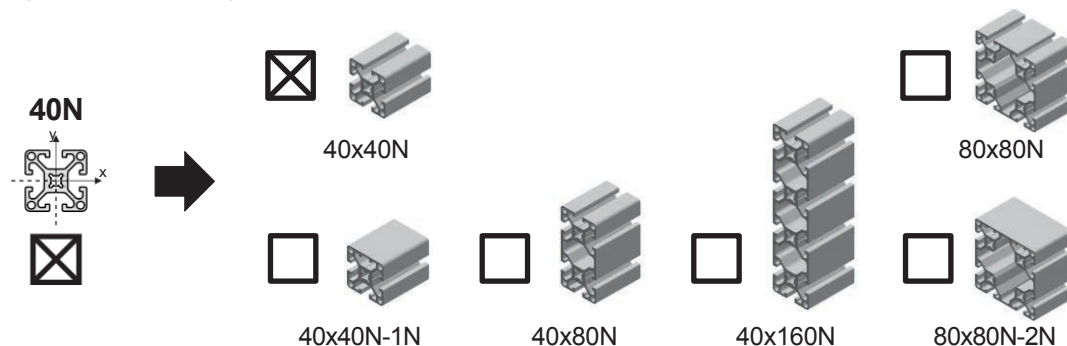

Pokračovat s výběrem spojky
Pokračovat s výběrem spojky Výchěr
upevnění



PRVKU ... A K VHODNÉMU SPOJOVACÍMU

... A SPRÁVNÝM KONEKTOREM
... A NAJÍT OPTIMÁLNÍ UPEVNĚNÍ



Výběr spojky

Nabídka společnosti MiroTechMont zahrnuje velké množství spojek s různými vlastnostmi a charakteristikami. Pomocí této tabulky můžete zkontrolovat, zda vlastnosti spojky splňují vaše požadavky.

Výběr konektoru

MiroTechMont vám nabízí velký výběr spojek s různými vlastnostmi a charakteristikami. Pomocí této tabulky můžete zjistit, zda spojka splňuje požadavky pro vaši aplikaci.

Výběr upevňovacích prvků

MTM vám nabízí velmi rozmanitou řadu upevňovacích prvků s různými vlastnostmi a specifikacemi. V této tabulce můžete zkontrolovat, které upevňovací prvky odpovídají požadavkům požadovaných aplikací, a provést tak první výběr.

	+++	+++	+	+++	+++	++	++	++	+++	+++
	Hohe Momentaufnahme / Vysoký moment / Captage important du moment									
	+++	+++	+++	+++	+++	+++	+++	+++	+++	+++
	Vysoká přenosová síla / Vysoká posuvná síla / Důležitý odběr posuvné síly									
	-	++	++	++	+++	++	++	++	-	+++
	Hohe Torsionsmomentaufnahme / Vysoký torzní moment / Captage important du moment de torsion									
	+	++	+	+	+++	+++	+++	+++	++	++
	Geringer Bearbeitungsaufwand / Minimální úprava profilu / Ne demande pas beaucoup d'usage									
	+++	++	+	++	+	+	++	++	+++	+++
	Geringer Montageaufwand / Minimální montáž / Temps de montage minime									
	+++	+++	++	++	++	+++	++	++	-	-
	Justierbarkeit / Možnost nastavení / Nastavitelné									
	++	++	-	-	-	+	-	-	++	+++
	Aufnahme von Flächenelementen / Podpora povrchových prvků / Accueil des éléments de surface									
+++	doporučeno		+++	doporučeno		+++	doporučeno		+++	doporučeno
++	vhodné		++	vhodný		++	vhodné		++	vhodné
+	funkční		+	funkční		+	funkční		+	funkční
-	nevhodný		-	nevhodný		-	nevhodné		-	nevhodné

Technické změny vyhrazeny

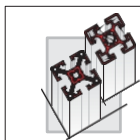

POPIS SYSTÉMU

POPIS SYSTÉMU POPIS SYSTÉMU

MM
mirotechmont



- **Rozsáhlý**
Systém profilů MTM je modulární stavebnice se základními prvky pro konstrukci racionalizačních a automatizačních zařízení a zařízení. Základ tvoří více než 150 standardních profilů vzpěr. Systém doplňují profily ve speciálním provedení.
- **Komplexní modulární systém**
Profilový systém MTM je modulární koncepce základních prvků pro konstrukci racionalizačních a automatizačních systémů a zařízení. Základem je více než 150 standardních profilů vzpěr. Systém doplňují profily ve speciálním provedení.
- **Široká škála produktů** S více než 150 standardními profily doplněnými speciálními profily nabízí systém MTM vysokou modularitu, která umožňuje konstrukci výkonných systémů racionalizace a automatizace.
- **Kompatibilní**
Profily řady 20 s drážkou 5, řady 30/40/80 s drážkou 8 a řady 45/60/90 a 50/100 s drážkou 10 jsou kompatibilní s běžnými provedeními na trhu.
- **Kompatibilní**
Profily řady 20 s šířkou drážky 5 mm, řady 30/40/80 s šířkou drážky 8 mm a řady 45/60/90 a 50/100 s šířkou drážky 10 mm nabízejí mimořádně ekonomickou volbu podle individuálních požadavků.
- **Kompatibilita**
Profily řady 20 s drážkou 5, řady 30/40/80 s drážkou 8 a řady 45/60/90 a 50/100 s drážkou 10 jsou kompatibilní s většinou profilů na trhu. Splňují nejnáročnější technické požadavky.
- **Ekonomické**
Díky široké škále hliníkových profilů lze podle technických požadavků vybrat nejvhodnější profil.
- **Zvláště široká řada**
Široká řada hliníkových profilů umožňuje najít řešení, které nejlépe vyhovuje vašim technickým a ekonomickým potřebám.
- **Flexibilní**
Flexibilní, ekonomický a modulární spojovací systém zajišťuje montáž všech dostupných profilů. Zvláštnost: Některé spojovací prvky umožňují kombinovat různé velikosti profilů a typy drážek.
- **Univerzální spojovací systém**
Flexibilní, ekonomický a modulární spojovací systém umožňuje téměř nekonečnou variabilitu konstrukcí. Mnoho upevňovacích prvků je kompatibilních s oběma typy drážek.
- **Všestrannost**
Díky standardizovaným a modulárně sestaveným prvkům je možné splnit téměř všechny konstrukční požadavky.
- **Mnoho možností použití** Rozmanitost standardizovaných prvků a modulární konstrukce umožňuje téměř nekonečnou škálu konstrukcí.
- **Vysoká kvalita**
Stabilní průřezy profilů, robustní provedení drážek, vysoká pevnost eloxování a stabilní a snadno montovatelná spojovací technika zaručují vysokou kvalitu.
- **Vysoká kvalita**
S našimi standardizovanými a modulárními prvky je možné zvládnout téměř všechny konstrukční výzvy.
- **Opakovaně použitelné**
Vysoká kvalita a odolnost umožňují opakované použití prvků. Flexibilní stavebnice zaručují plynulou další výstavbu a kdykoli možné přizpůsobení zařízení změněným úkolům.
- **Všestrannost**
S našimi standardizovanými a modulárními prvky je možné zvládnout téměř všechny konstrukční výzvy.
- **Vysoká kvalita**
Robustní profily, pevné drážky, vysoká odolnost eloxování a robustní, snadno montovatelný spojovací systém nabízejí vysokou kvalitu.
- **Flexibilita použití a recyklovatelnost**
Vysoká kvalita a robustnost našich prvků zaručuje jejich dlouhou životnost. Modulární konstrukce nabízí možnost montáže těchto prvků na již existující konstrukce a umožňuje nové úpravy v závislosti na vývoji stavebních požadavků.
- **Flexibilní použití a opakovaná použitelnost** Tato úroveň kvality a odolnosti zajišťuje dlouhou životnost, opakovanou použitelnost a flexibilitu našich prvků. Modulární koncepce zaručuje konzistentní rozšiřování a úpravy instalací v závislosti na změnách požadavků a situací.

PROFIL-ÜBERSICHT PŘEHLED PROFILŮ PANORAMA DES PROFILES

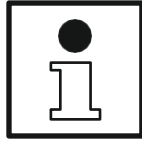

■ 2,02

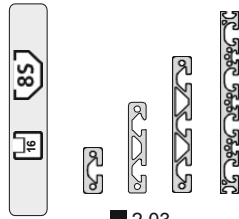

■ 2,03

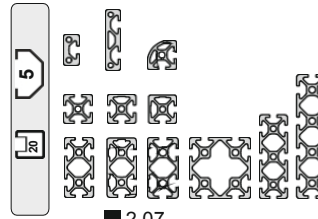

■ 2,07

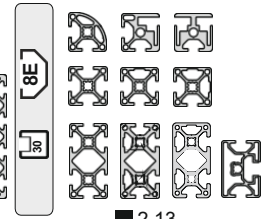

■ 2,13

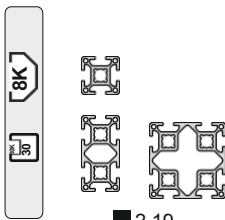

■ 2,19

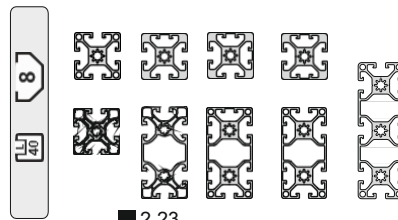

■ 2,23

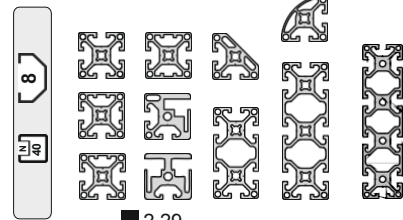

■ 2,29

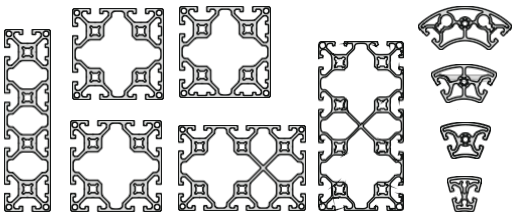

■ 2,39

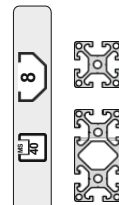

■ 2,43

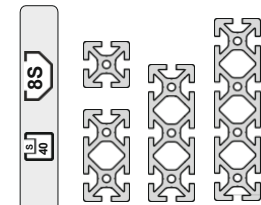

■ 2,47

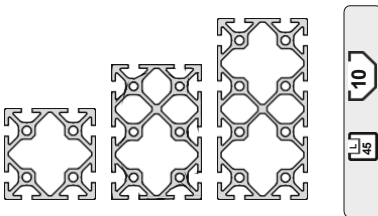

■ 2,55

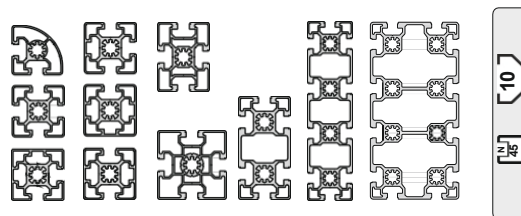

■ 2,63

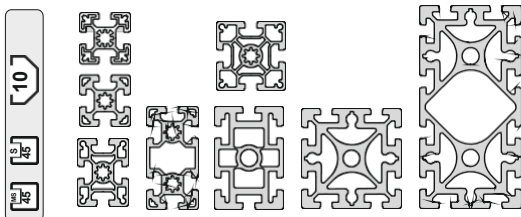

■ 2,67

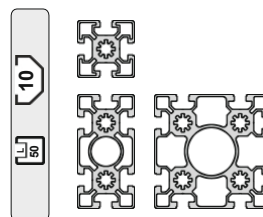

■ 2,71

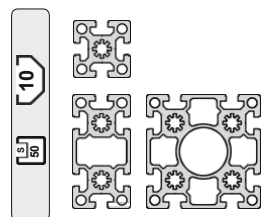

■ 2,75

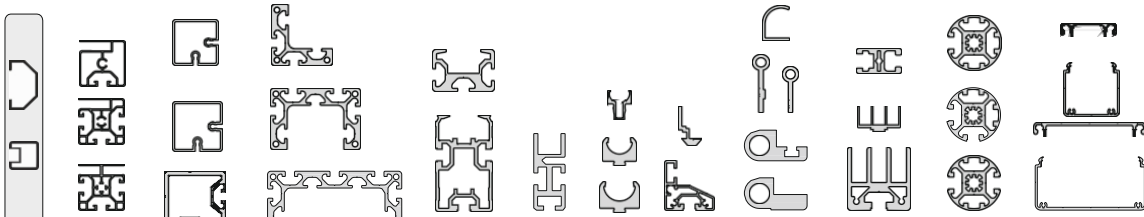

■ 2,79

Technické změny vyhrazeny

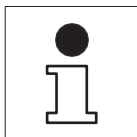

• **Tlačené profily podle DIN EN 12020**
(náhrada za DIN 17615)

Materiál Al Mg Si 0,5 F25
Číslo materiálu 3.3206.72
(tepelně vytvrzený)

- **Dodací délka** (pokud není uvedeno jinak) 6040 mm
Funkční délka (pokud není uvedeno jinak) 6000 mm
Tolerance řezu pro všechny délky +/- 1 mm

• **Mechanické údaje**
(ve směru lisování)

Pevnost v tahu R_m min. 250 N/mm²
Meze kluzu R_p 0,2 min. 200 N/mm²
Mez kluzu A 5 min. 10
Meze kluzu A10 min. 8
Modul pružnosti ca. 70 000 N/mm²
Tvrdost podle Brinella cca. 75 HB
Koeficient délkové roztažnosti (při 20–100 °C) $23,6 \times 10^{-6}$ 1/K

• **Povrch**

Matný, mořený E6 / Ev1
Tloušťka eloxované vrstvy cca 15 µm
Tvrdost eloxované vrstvy cca 270–320 HV

• **Extrudované profily v souladu s normou DIN EN 12020**
(Náhrada za DIN 17615)

Materiál: Al Mg Si 0,5 F25
Číslo materiálu: 3.3206.72
(vypálené v peci)

- **Dodávaná délka** (pokud není uvedeno jinak) 6040 mm
Funkční délka (pokud není uvedeno jinak) 6000 mm
Tolerance pro všechny délky +/- 1 mm

• **Mechanické údaje**
(ve směru lisování)

Pevnost v tahu R_m min. 250 N/mm²
Meze kluzu R_p 0,2 min. 200 N/mm²
Meze kluzu A 5 min. 10
Meze kluzu A10 min. 8
Modul pružnosti ca. 70 000 N/mm²
Tvrdost podle Brinella cca. 75 HB
Koeficient lineární roztažnosti (při 20–100 °C) $23,6 \times 10^{-6}$ 1/K

• **Povrch**

Mrtvý ponor E6 / Ev1
Tloušťka eloxované vrstvy cca 15 µm
Pevnost eloxované vrstvy cca 270–320 HV

• **Profilé extrudované podle DIN EN 12020**
(nahrazuje normu DIN 17615)

Materiál Al Mg Si 0,5 F25
Číslo materiálu 3.3206.72
(termozpevněný)

- **Dodávaná délka** (pokud není uvedeno jinak) 6040 mm
Funkční délka (pokud není uvedeno jinak) 6000 mm
Tolerance +/- 1 mm

• **Mechanické vlastnosti**
(směr vytlačování)

Pevnost v tahu R_m min. 250 N/mm²
Mez kluzu R_p 0,2 min. 200 N/mm²
Prodloužení při přetržení A 5 min. 10
Prodloužení při přetržení A10 min. 8 %
Koeficient elasticity cca 70 000 N/mm²
Tvrdost podle Brinella cca. 75 HB
Koeficient lineární tepelné roztažnosti (od 20 do 100 °C) $23,6 \times 10^{-6}$ 1/K

• **Povrch**

Matovaný E6 / Ev1
Tloušťka vrstvy eloxování cca 15 µm
Tvrdost eloxování cca 270–320 HV

Tolerance zkroucení v podélném směru profilu

Podélná torzní tolerance profilu
Tolerance torze v podélném směru profilu

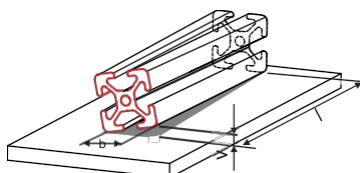

b (mm) od do	v při délkách l (mm)			
	1 000	2 000	4 000	6 000
20 45	1,0	1,2	1,8	2,0
45 70	1,0	1,2	1,5	2,0
75 100	1,0	1,5	2,2	3,0
125 150	1,2	1,5	2,2	3,0

Tolerance přímosti v podélném směru profilu

Tolerance podélné rovinnosti profilu
Příčná tolerance v podélném směru profilu

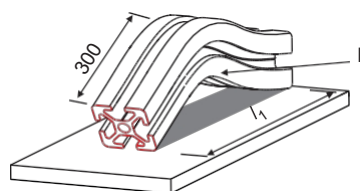

Délka l1 (mm)	h (mm)
až 1 000	0,7
až 2 000	1,3
až 3 000	1,8
až 4 000	2,2
až 5 000	2,6
až 6 000	3,0

Úhlová tolerance (tolerance sklonu)

Úhlová tolerance (tolerance sklonu)
Úhlová tolerance (tolerance sklonu)

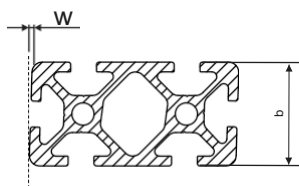

Šířka b (mm)	Tolerance w (mm)
0	0,2
20 - 40	0,4
40 - 80	0,6
80 - 120	0,8
120	1,2



Konkávita

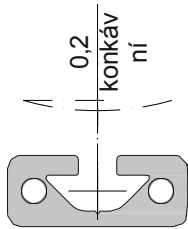

16x40S	16x80S	16x120S	16x160
■ 2,05	■ 2,05	■ 2,05	■ 2,06

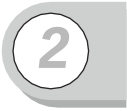

Matice 

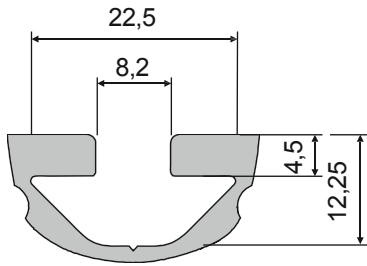

Kernloch

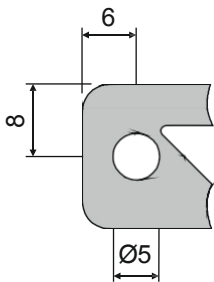

Vnější hrana

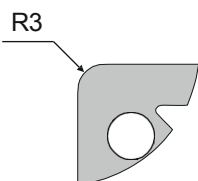

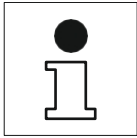

Průhyb profilů
Průhyb profilů Flexion
des profilés

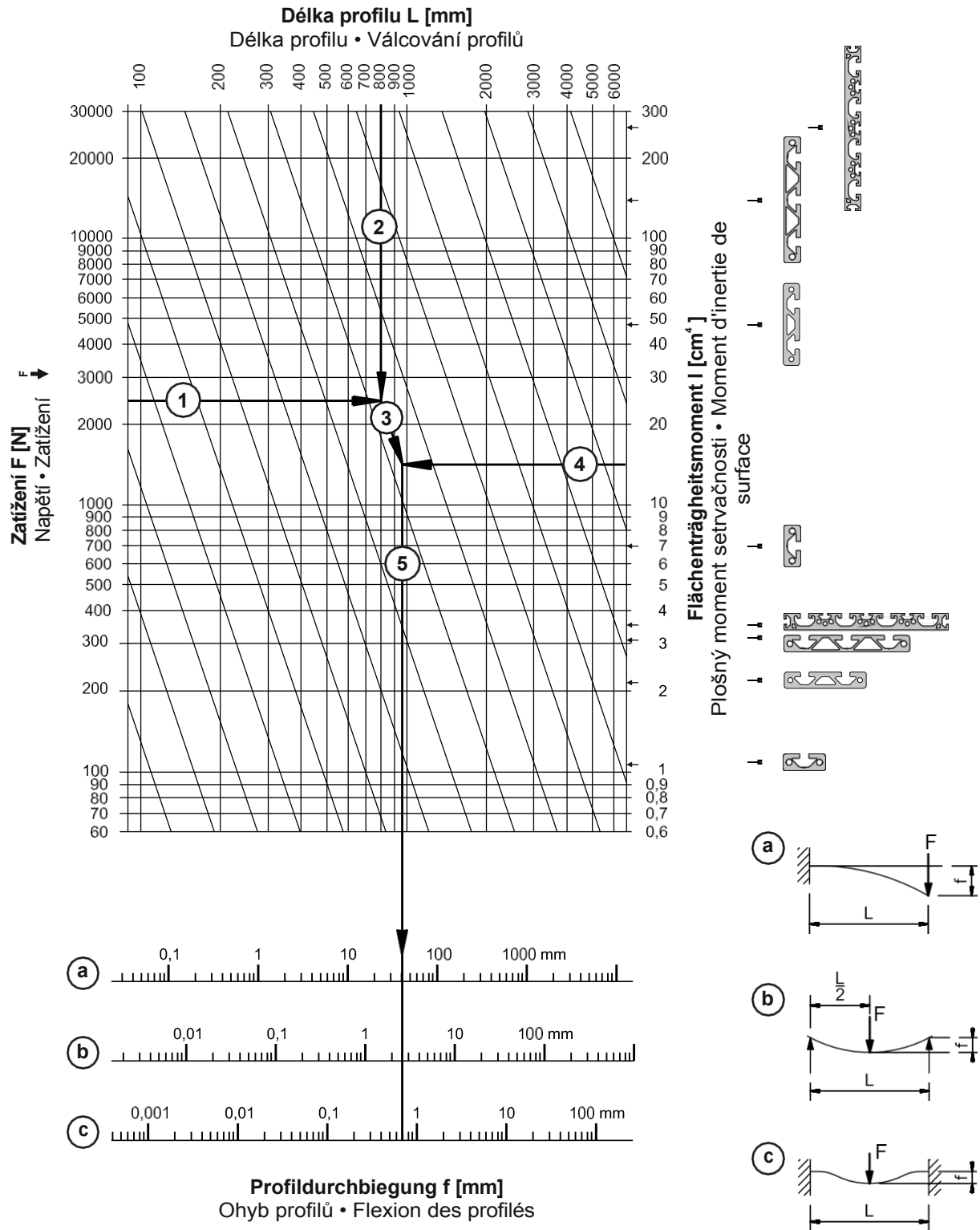

Technické změny vyhrazeny

PROFILY
PROFILY
PROFILE ALU-



16x40 S

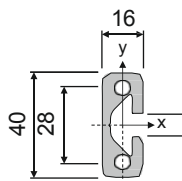

05.01045.00

$$\begin{aligned} &= 1,16 \text{ kg/m} \\ I_x &= 7,10 \text{ cm}^4 \quad W \\ &= 3,55 \text{ cm}^3 \quad I \\ &= 1,10 \text{ cm}^4 \quad W = \\ &1,38 \text{ cm}^3 \end{aligned}$$

PE (m)
6 / 60 / 120

2

16x80 S

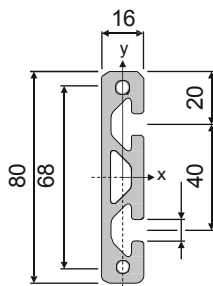

05.01813.00

$$\begin{aligned} M &= 2,14 \text{ kg/m} \\ I_x &= 48,75 \text{ cm}^4 \\ W_x &= 12,19 \text{ cm}^3 \quad I \\ &= 2,20 \text{ cm}^4 \\ \check{S}_y &= 2,75 \text{ cm}^3 \end{aligned}$$

PE (m)
6 / 60 / 120

16x120 S

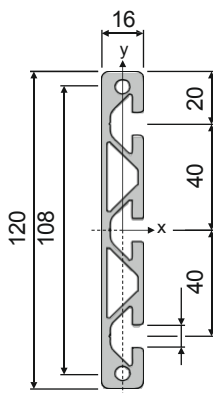

05.01806.00

$$\begin{aligned} &= 2,79 \text{ kg/m} \\ I_x &= 148,38 \text{ cm}^4 \quad W \\ &= 24,73 \text{ cm}^3 \quad I \\ &= 3,07 \text{ cm}^4 \\ \check{S}_y &= 3,84 \text{ cm}^3 \end{aligned}$$

PE (m)
6 / 60 / 120

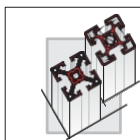

ALU-PROFILE PROFILY PROFILY



16x160

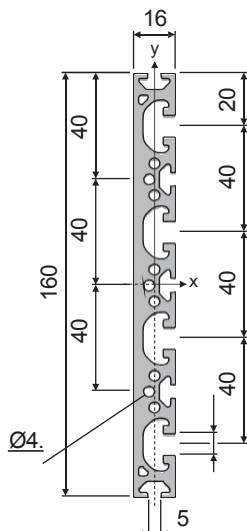
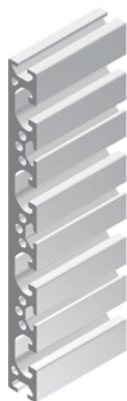

05.01805.00

M = 3,87 kg/m
 $I_x = 298,20 \text{ cm}^4$ W
 $I_x = 37,28 \text{ cm}^3$ I
 $I_x = 3,91 \text{ cm}^4$
 $S_y = 4,89 \text{ cm}^3$

PE (m)
 6 / 60 / 120

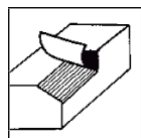

PROFILBEARBEITUNG DOKONČOVÁNÍ PROFILŮ USINAGE DE PROFILES

↓ ↓ ↓ ↓ ↓ ↓ ↓ ↓ ↓ ↓ ↓
16x40 **16x80** **16x120** **16x160**

			05.xxxxx.09			
VSI 7			05.xxxxx.15 ■ 3,21	VSA 14	05.xxxxx.45 ■ 3,20	
VSI 7			05.xxxxx.16	VSA 14	VSA 14	05.xxxxx.46



Technické změny vyhrazeny



Konkávita

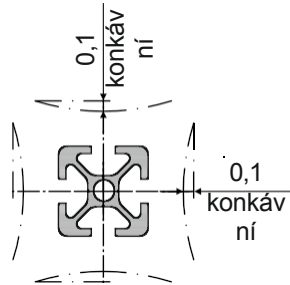

Mat ice

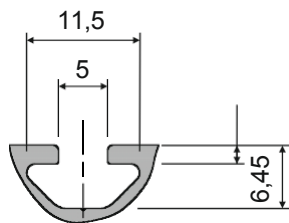

Jádrový otvor

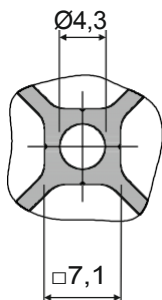

Vnější hrana

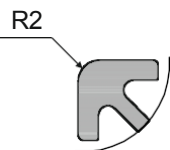

10x20	10x40		
■ 2,09	■ 2,09		
20x20	20x20-1N	20x20-2N90	20x20-R
■ 2,09	■ 2,09	■ 2,10	■ 2,10
20x40	20x40-2N	20x40-3N90	
■ 2,10	■ 2,10	■ 2,11	
20x60	20x80	40x40	
■ 2,11	■ 2,11	■ 2,11	

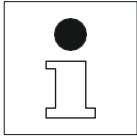

Průhyb profilů
 Průhyb profilů Flexion
 des profilés

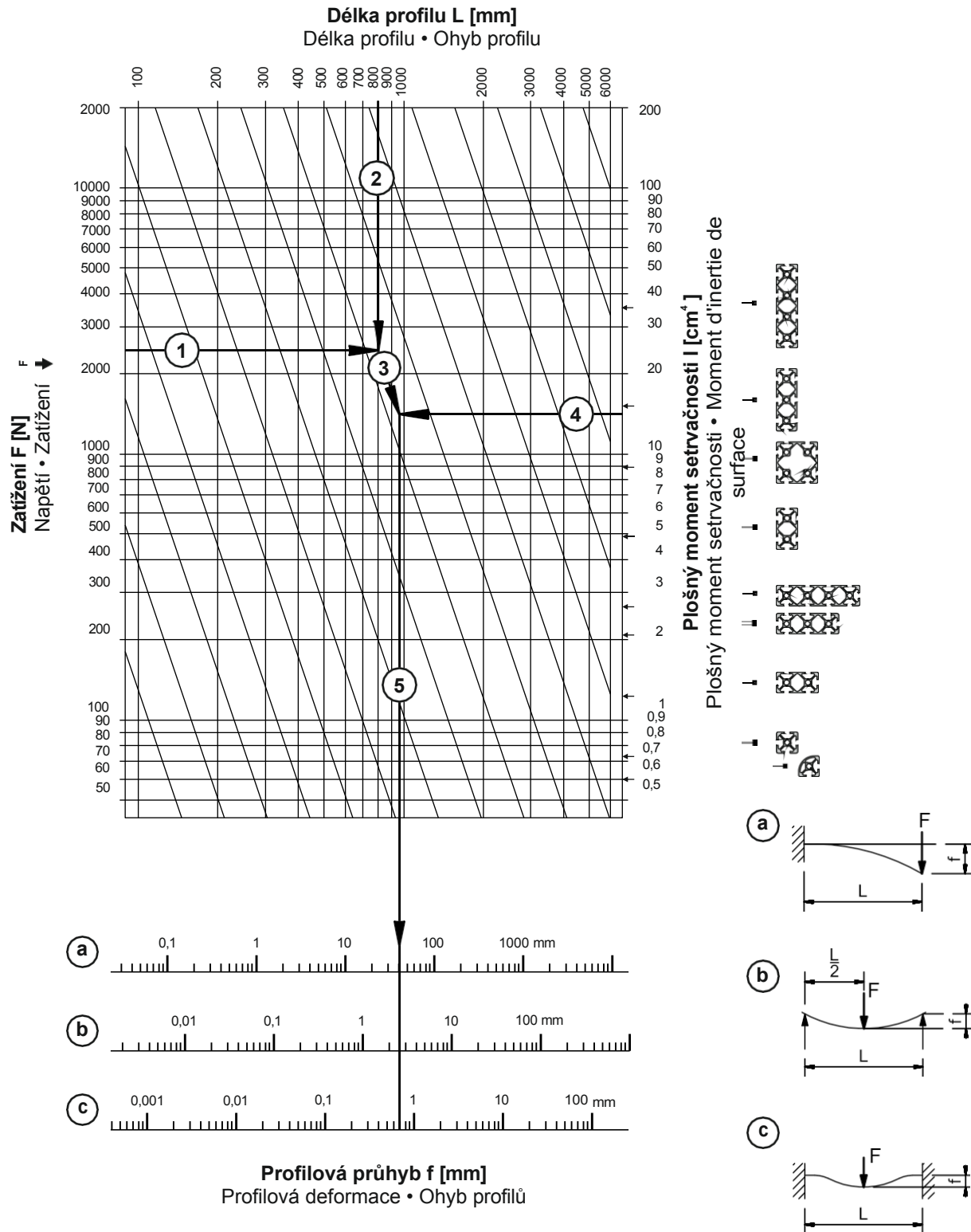

10x20

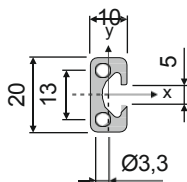

05.01602.00

$M = 0,35 \text{ kg/m}$
 $I_x = 0,53 \text{ cm}^4$
 $W_x = 0,53 \text{ cm}^3$
 $I_y = 0,13 \text{ cm}^4$
 $W_y = 0,26 \text{ cm}^3$

PE (m)
6

10x40

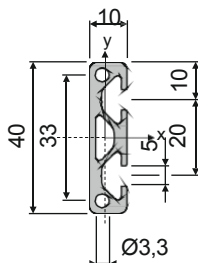
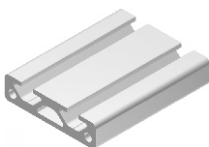

05.01603.00

$M = 0,63 \text{ kg/m}$
 $I_x = 3,56 \text{ cm}^4$
 $W_x = 7,12 \text{ cm}^3$
 $I_y = 0,35 \text{ cm}^4$
 $W_y = 0,18 \text{ cm}^3$

PE (m)
6

20x20

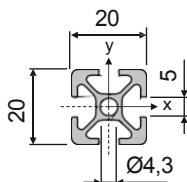
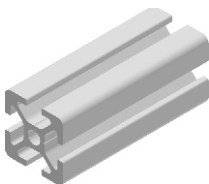

05.01605.00

$M = 0,48 \text{ kg/m}$
 $I_x = 0,74 \text{ cm}^4$
 $W_x = 0,74 \text{ cm}^3$
 $I_y = 0,74 \text{ cm}^4$
 $W_y = 0,74 \text{ cm}^3$

PE (m)
6 / 96 / 192

20x20-1N

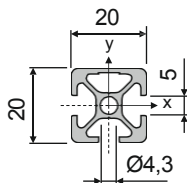
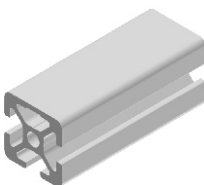

05.01645.00

$M = 0,50 \text{ kg/m}$
 $I_x = 0,74 \text{ cm}^4$
 $W_x = 0,74 \text{ cm}^3$
 $I_y = 0,80 \text{ cm}^4$
 $W_y = 0,80 \text{ cm}^3$

PE (m)
6 / 96 / 192

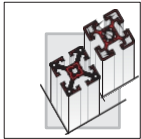

ALU-PROFILE PROFILY PROFILY



20x20-2N90

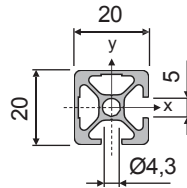
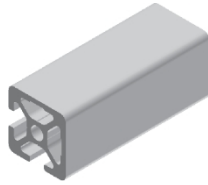

05.01646.00

$M = 0,52 \text{ kg/m}$
 $I_x = 0,80 \text{ cm}^4$ $W_x = 0,80 \text{ cm}^3$
 $I_y = 0,80 \text{ cm}^4$ $W_y = 0,80 \text{ cm}^3$
 PE (m)
 6 / 96 / 192

20x20-R

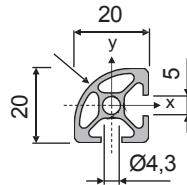
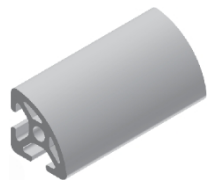

05.01024.00

$M = 0,47 \text{ kg/m}$
 $I_x = 0,66 \text{ cm}^4$ $W_x = 0,66 \text{ cm}^3$
 $I_y = 0,66 \text{ cm}^4$ $W_y = 0,66 \text{ cm}^3$
 PE (m)
 6

20x40

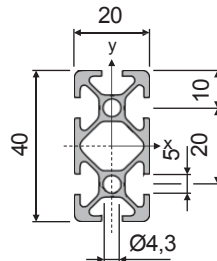
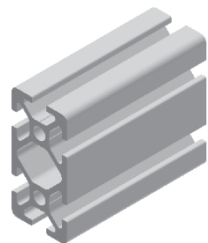

05.01606.00

$M = 0,85 \text{ kg/m}$
 $I_x = 5,01 \text{ cm}^4$ $S_x = 2,51 \text{ cm}^3$
 $I_y = 1,36 \text{ cm}^4$ $W_y = 1,36 \text{ cm}^3$
 PE (m)
 6 / 96 / 192

20x40-2N

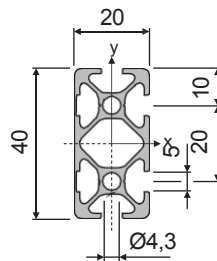
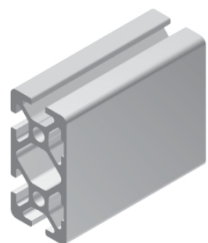

05.01658.00

$M = 0,89 \text{ kg/m}$
 $I_x = 5,27 \text{ cm}^4$ $S_x = 2,64 \text{ cm}^3$
 $I_y = 1,44 \text{ cm}^4$ $W_y = 1,44 \text{ cm}^3$
 PE (m)
 3

Technické změny vyhrazeny

20x40-3N90

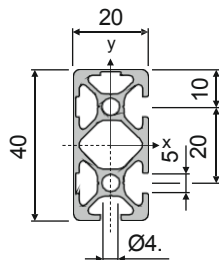
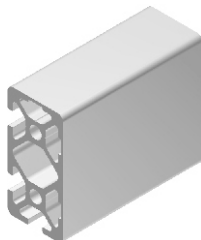

05.01659.00

$$M = 0,89 \text{ kg/m } I = 5,27 \text{ cm}^4$$

$$W_x = 2,64 \text{ cm}^3 \quad I_y = 1,44 \text{ cm}^4 \quad W_y = 1,44 \text{ cm}^3$$

PE (m)
6 / 96 / 192

20x60

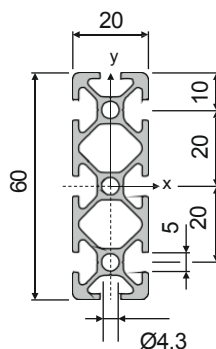
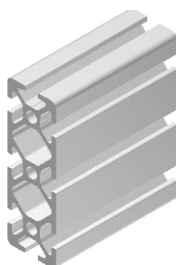

05.01663.00

$$M = 1,24 \text{ kg/m}$$

$$I_x = 16,09 \text{ cm}^4 \quad W_x = 5,36 \text{ cm}^3$$

$$I_y = 2,06 \text{ cm}^4 \quad S_y = 2,06 \text{ cm}^3$$

PE (m)
6 / 24

20x80

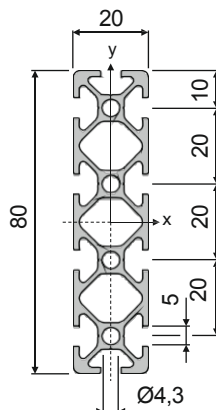
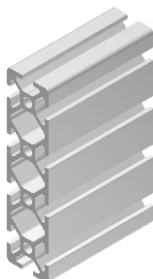

05.01664.00

$$M = 1,62 \text{ kg/m}$$

$$I_x = 36,08 \text{ cm}^4 \quad S_x = 9,02 \text{ cm}^3$$

$$I_y = 2,72 \text{ cm}^4 \quad S_y = 2,72 \text{ cm}^3$$

PE (m)
6 / 24

40x40

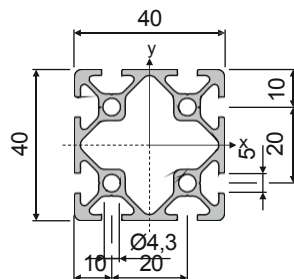
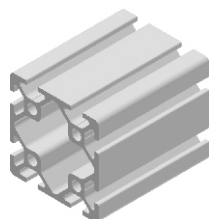

05.01607.00

$$M = 1,33 \text{ kg/m}$$

$$I_x = 8,92 \text{ cm}^4 \quad S_x = 4,46 \text{ cm}^3$$

$$I_y = 8,92 \text{ cm}^4 \quad S_y = 4,46 \text{ cm}^3$$

PE (m)
6

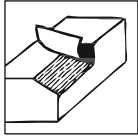

PROFILBEARBEITUNG DOKONČOVÁNÍ PROFILŮ USINAGE DE PROFILES

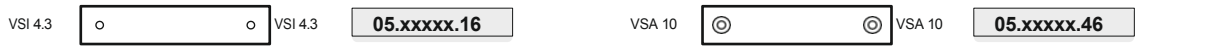
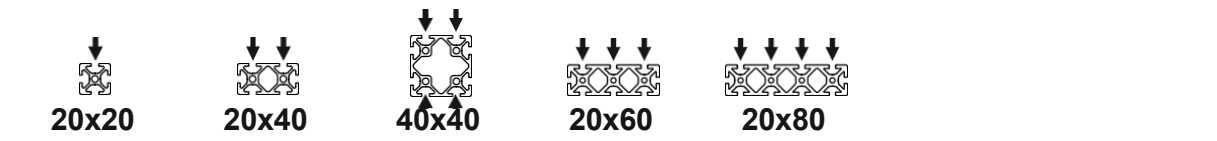
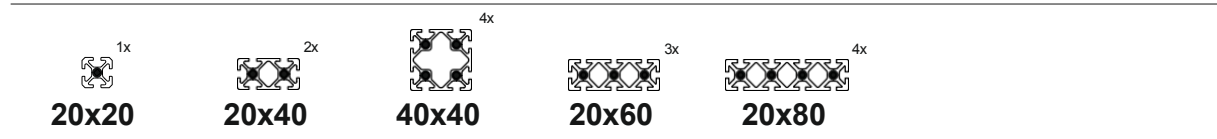

Technické změny vyhrazeny

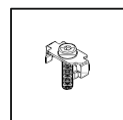
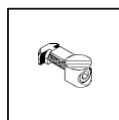
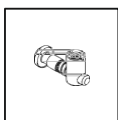



Konkávita

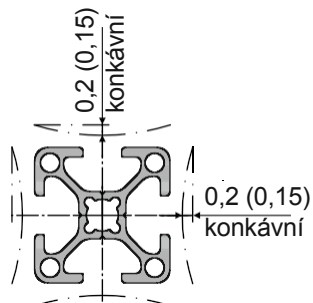

Mat ice

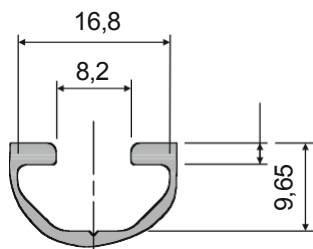

Kernloch

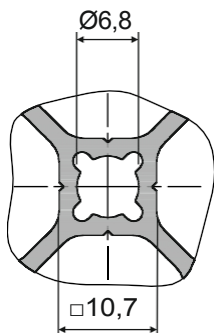

Vnější hrana

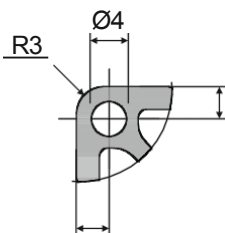

30x30	30x30-1N	30x30-2N90	30x30-R
■ 2,15	■ 2,15	■ 2,15	■ 2,15
30x45	30x60	30x60-2N	30x60-3N90
■ 2,15	■ 2,16	■ 2,16	■ 2,16
30x30KL	30x30KL-180°		
➔ ■ 2,17	➔ ■ 2,17		



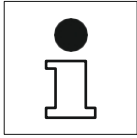

Průhyb profilů
 Průhyb profilů Flexion
 des profilés

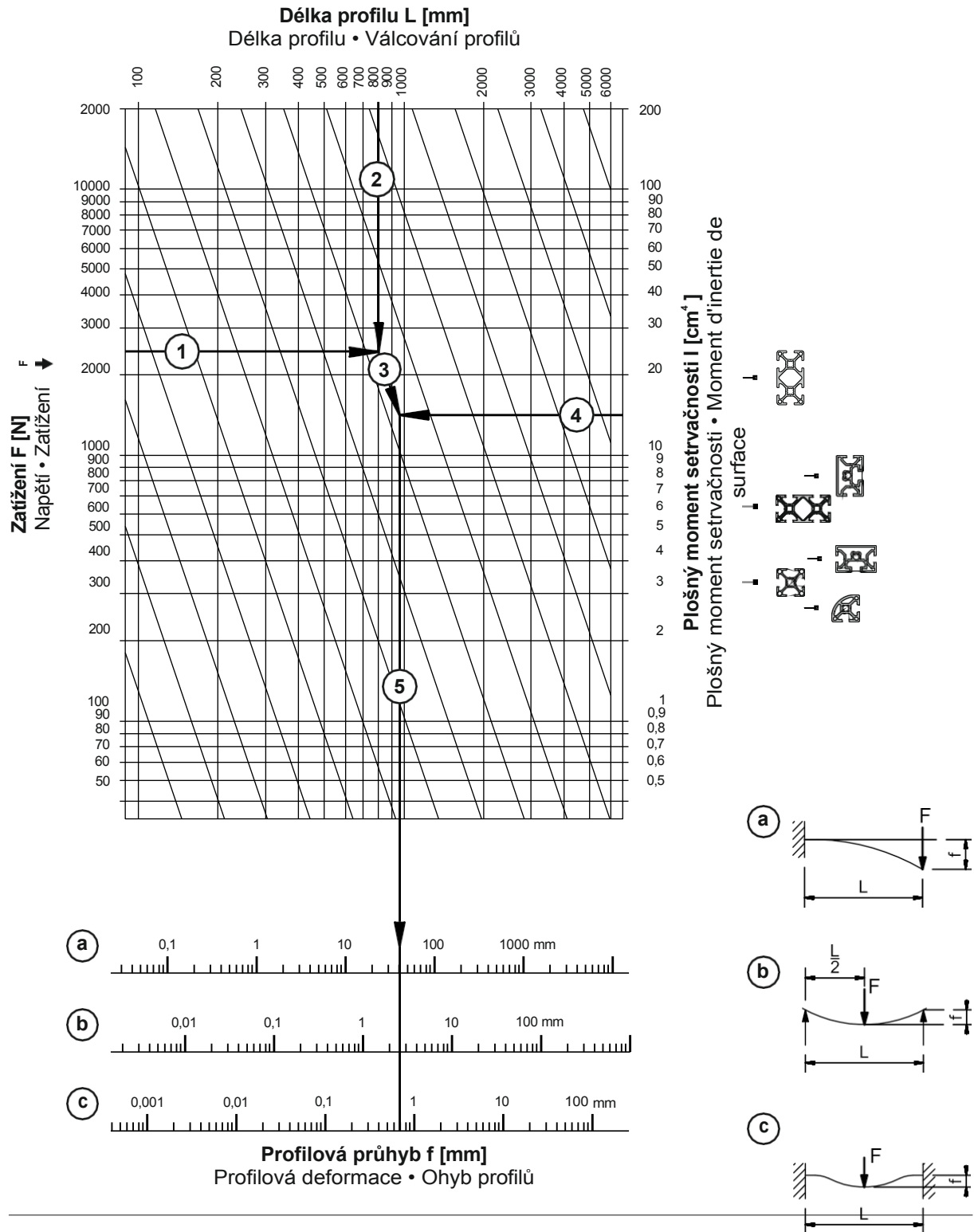

Technické změny vyznačeny



30x30

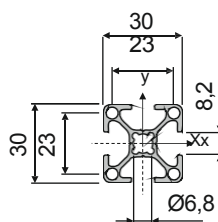
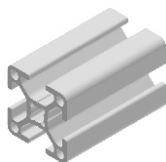

05.01025.00

M = 0,81 kg/m
 $I_x = 2,78 \text{ cm}^4$
 $W_x = 1,85 \text{ cm}^3$
 $I_y = 2,78 \text{ cm}^4$
 $S_y = 1,85 \text{ cm}^3$
 PE (m)
 6 / 72 / 144

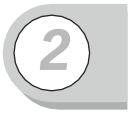

30x30-1N

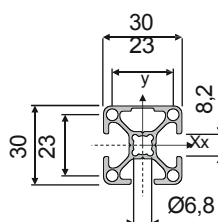
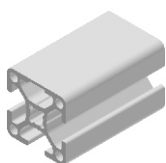

05.01915.00

M = 0,84 kg/m
 $I_x = 2,95 \text{ cm}^4$
 $W_x = 1,97 \text{ cm}^3$
 $I_y = 2,78 \text{ cm}^4$
 $S_y = 1,85 \text{ cm}^3$
 PE (m)
 6 / 72 / 144

30x30-2N90

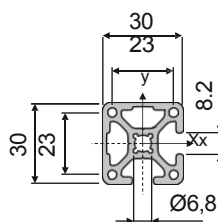
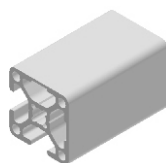

05.01916.00

M = 0,86 kg/m
 $I_x = 2,96 \text{ cm}^4$
 $W_x = 1,97 \text{ cm}^3$
 $I_y = 2,96 \text{ cm}^4$
 $S_y = 1,97 \text{ cm}^3$
 PE (m)
 6 / 72 / 144

30x30-R

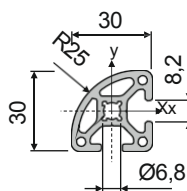
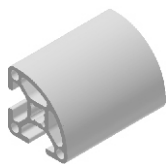

05.01925.00

M = 0,80 kg/m
 $I_x = 2,40 \text{ cm}^4$
 $W_x = 1,60 \text{ cm}^3$
 $I_y = 2,40 \text{ cm}^4$
 $S_y = 1,60 \text{ cm}^3$
 PE (m)
 6 / 72 / 144

30x45

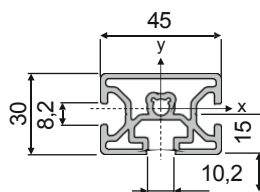
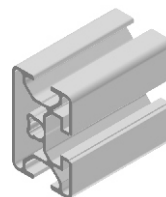

05.01923.00

M = 1,05 kg/m
 $I_x = 7,97 \text{ cm}^4$
 $S_x = 3,54 \text{ cm}^3$
 $I_y = 3,75 \text{ cm}^4$
 $S_y = 2,51 \text{ cm}^3$
 PE (m)
 6 / 24 / 48 / 72

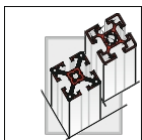

ALU-PROFILE PROFILY PROFILY



30x60

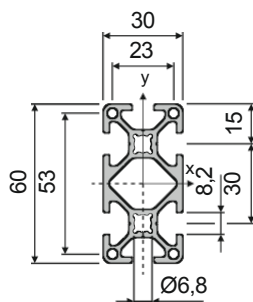
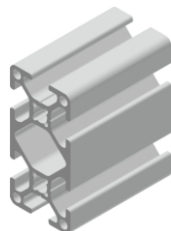

05.01924.00

M = 1,50 kg/m
 $I_x = 19,10 \text{ cm}^4$
 $W_x = 6,60 \text{ cm}^3$
 $I_y = 5,64 \text{ cm}^4$
 $W_y = 3,76 \text{ cm}^3$

PE (m)
 6 / 36 / 72 / 108

30x60-2N

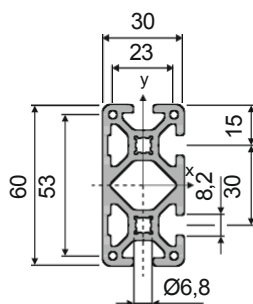
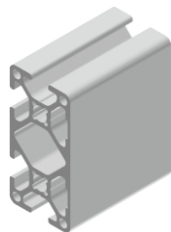

05.01933.00

M = 1,61 kg/m
 $I_x = 20,48 \text{ cm}^4$
 $W_x = 6,83 \text{ cm}^3$
 $I_y^x = 6,07 \text{ cm}^4$
 $S_y = 4,05 \text{ cm}^3$

PE (m)
 3

30x60-3N90

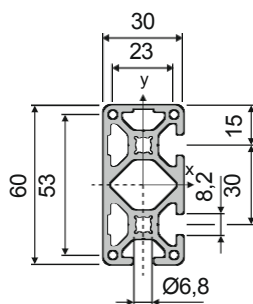
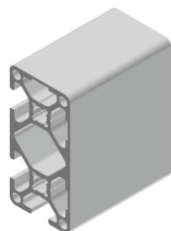

05.01928.00

M = 1,61 kg/m
 $I_x = 20,48 \text{ cm}^4$
 $W_x = 6,83 \text{ cm}^3$
 $I_y^x = 6,07 \text{ cm}^4$
 $S_y = 4,05 \text{ cm}^3$

PE (m)
 6 / 36 / 72 / 108

KLEMMPROFILE UPÍNACÍ PROFILY PROFILE DE SERRAGE



30x30 KL

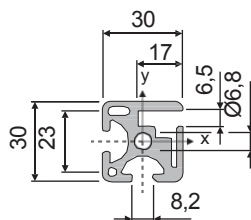

05.01919.00

M = 1,04 kg/m
I_x = 3,40 cm⁴
S = 2,27 cm³
I_y = 3,10 cm⁴
W_y = 2,07 cm³

PE (m)
6 / 72 / 144

Klemmleiste und Schrauben nicht im Lieferumfang enthalten
Upínací lišty a šrouby nejsou součástí dodávky
Baguette a šrouby nejsou součástí balení

2

30x30 KL-180°

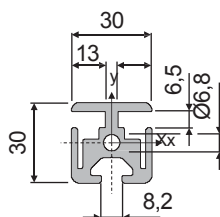

05.01921.00

M = 1,16 kg/m
I_x = 3,61 cm⁴ W
= 2,41 cm³ I
= 3,45 cm⁴ W =
2,30 cm³

PE (m)
6 / 72 / 144

Klemmleiste und Schrauben nicht im Lieferumfang enthalten
Upínací lišty a šrouby nejsou součástí dodávky
Baguette et vis ne sont pas inclus

Klemmleiste

Svorníky · Bageta

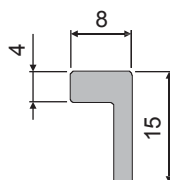

05.01922.00

PE (m)
6



99,00095,00

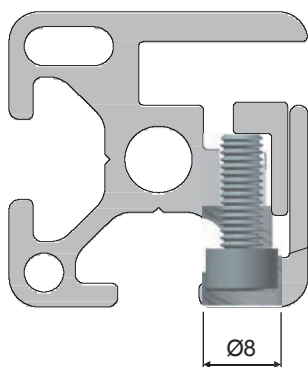

M4x12, DIN 7984
Objednejte prosím samostatně
Objednejte prosím samostatně

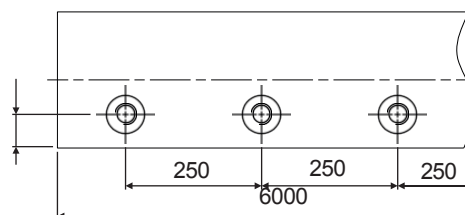

Otvory již jsou v profilu k dispozici Otvory
již jsou v profilu k dispozici Profilés déjà
usinés

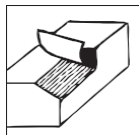

PROFILBEARBEITUNG

DOKONČOVÁNÍ PROFILŮ

USINAGE DE PROFILES



		05.xxxxx.09
M8x30		05.xxxxx.10
M8x30		05.xxxxx.11

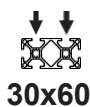

VSI 7		05.xxxxx.15 ■ 3,21
VSI 7		05.xxxxx.16
BV11		05.xxxxx.25 ■ 3.06
BV11		05.xxxxx.26
GV10.5		05.xxxxx.30 ■ 3.02
GV10.5		05.xxxxx.31

UNI		05.xxxxx.40 ■ 3,11
UNI		05.xxxxx.41
VSA 14		05.xxxxx.45 ■ 3,20
VSA 14		05.xxxxx.46



BV11V		05.xxxxx.85 ■ 3,06
BV11V		05.xxxxx.86

UNI		05.xxxxx.43 ■ 3,11
UNI		05.xxxxx.44

Technické změny vyhrazeny

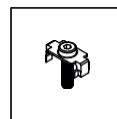
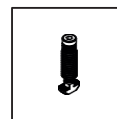
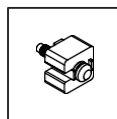
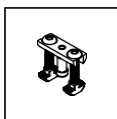
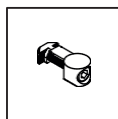
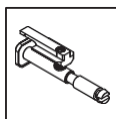
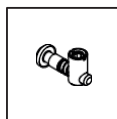



Konkávita

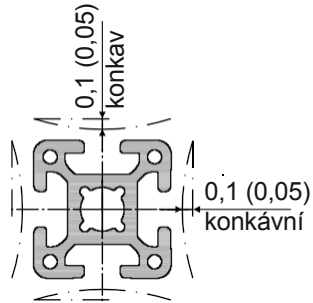

30x30-10K



■ 2,21

30x60-10K



■ 2,21

60x60-10K

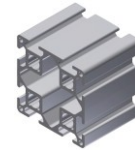

■ 2,21

2

Matice

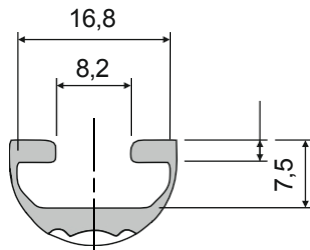

Kernloch

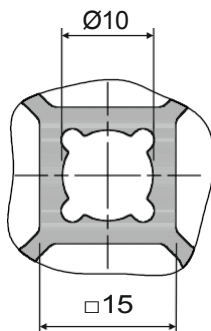

Vnější hrana

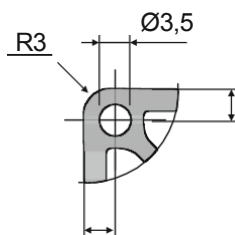

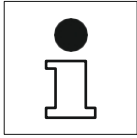

Průhyb profilů

Ohyb profilů Flexion des profilés

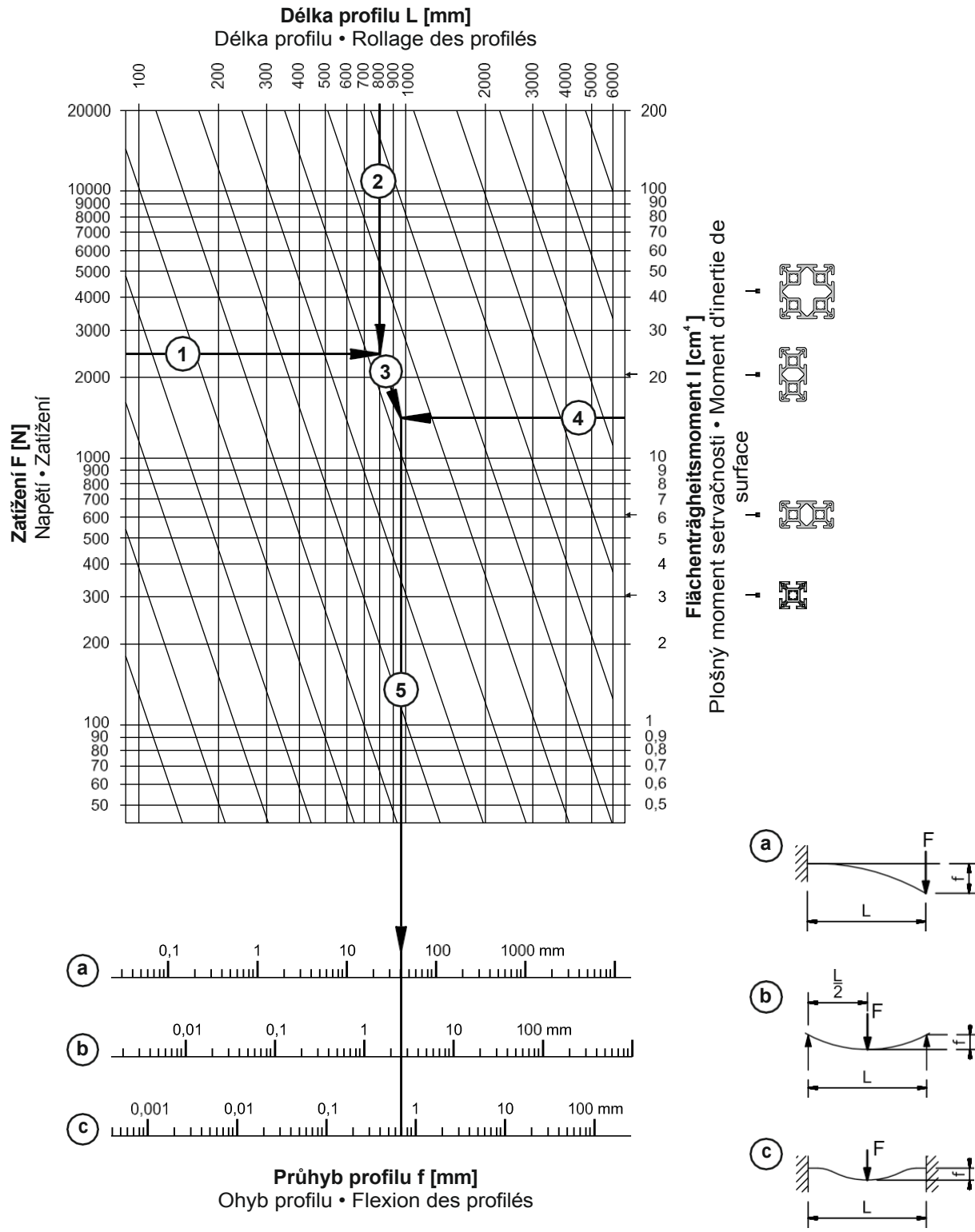

Technické změny vyhrazeny

30x30-10K

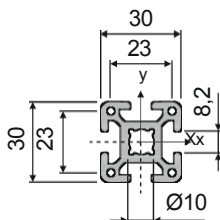

05.01926.00

M = 0,97 kg/m
 $I_x = 3,17 \text{ cm}^4$
 $S_x = 2,11 \text{ cm}^3$
 $I_y = 3,17 \text{ cm}^4$
 $S_y = 2,11 \text{ cm}^3$

PE (m)
 6 / 72 / 144

2

30x60-10K

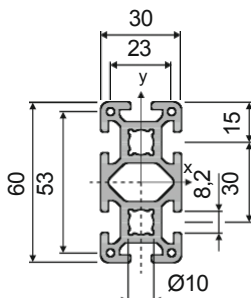
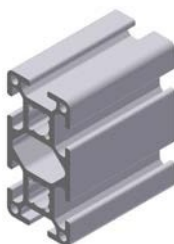

05.01927.00

M = 1,81 kg/m
 $I_x = 22,55 \text{ cm}^4$
 $S_x = 7,52 \text{ cm}^3$
 $I_y = 6,33 \text{ cm}^4$
 $S_y = 4,22 \text{ cm}^3$

PE (m)
 6 / 36 / 72 / 108

60x60-10K

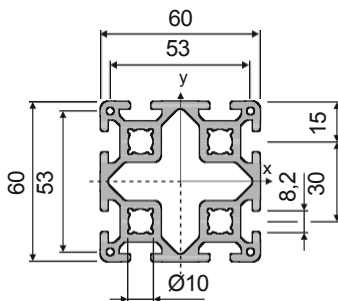
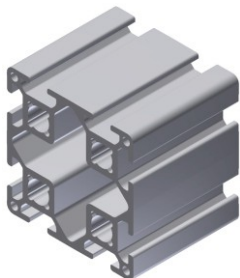

05.01960.00

M = 3,00 kg/m
 $I_x = 42,67 \text{ cm}^4$
 $S_x = 14,22 \text{ cm}^3$
 $I_y = 42,67 \text{ cm}^4$
 $S_y = 14,22 \text{ cm}^3$

PE (m)
 6 / 36 / 72 / 108

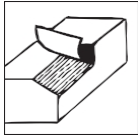

PROFILBEARBEITUNG

PROFILOVÉ DOKONČOVÁNÍ

USINAGE DE PROFILES



30x30-10K



05.xxxxx.09



30x60-10K

M12x60



05.xxxxx.10

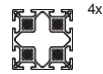

60x60-10K

M12x60



M12x60

05.xxxxx.11



30x30-10K

VSI 7



05.xxxxx.15

■ 3,21



30x60-10K

VSI 7

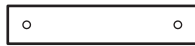

VSI 7

05.xxxxx.16



60x60-10K

VSA 14



05.xxxxx.45

■ 3,20

VSA 14

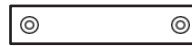

VSA 14

05.xxxxx.46

BV11

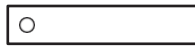

05.xxxxx.25

■ 3.06

BV11

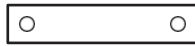

BV11

05.xxxxx.26

GV



05.xxxxx.30

■ 3,02

GV



GV

05.xxxxx.31



30x60-10K

BV11V



05.xxxxx.85

■ 3,06

BV11V



BV11V

05.xxxxx.86

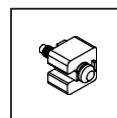
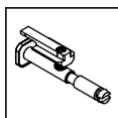
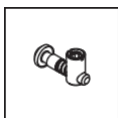



Konkávita

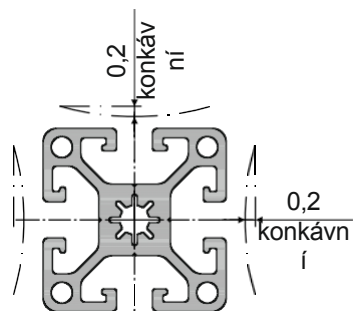

Matice

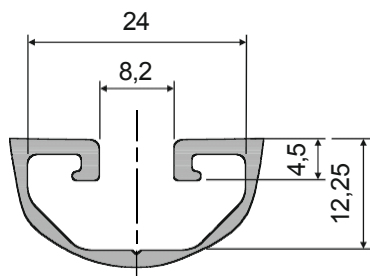

Kernloch

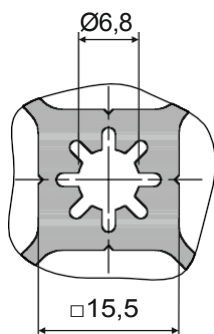

Vnější hrana

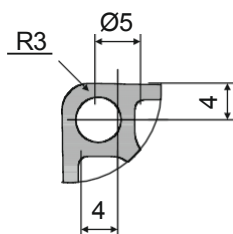

40x40EL-1,4



■ 2,25

40x40L-1,55



■ 2,25

40x40L-1N



■ 2,25

40x40L-2N90



■ 2,25

40x40L-2N180



■ 2,25

40x80EL-2,45

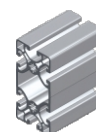

■ 2,26

40x80L-2,65

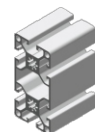

■ 2,26

40x80L-2N

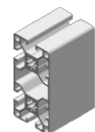

■ 2,26

40x80L-3N



■ 2,27

40x120L

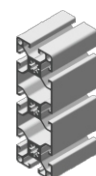

■ 2,27

80x80L

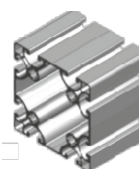

■ 2,27

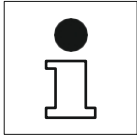

Průhyb profilů
 Průhyb profilů Flexion
 des profilés

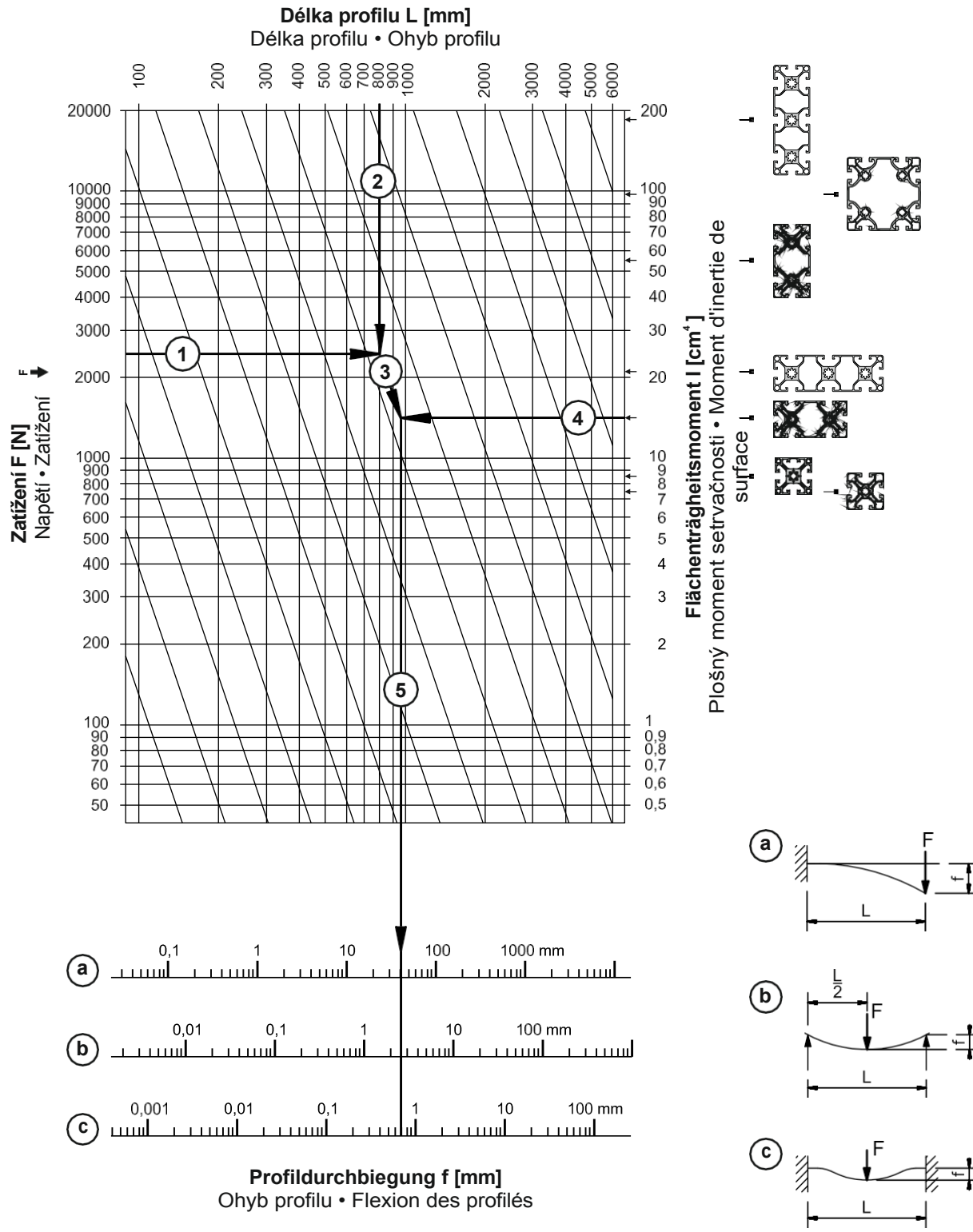

Technické změny vyznačeny

PROFILY
ALU-PROFIL
 PROFILY



40x40 EL-1,4

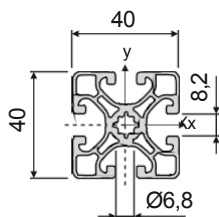
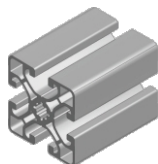

05.02163.00

$M = 1,37 \text{ kg/m}$
 $I_x = 7,42 \text{ cm}^4$
 $W_x = 3,71 \text{ cm}^3$
 $I_y = 7,42 \text{ cm}^4$
 $W_y = 3,71 \text{ cm}^3$

PE (m)
 6 / 48 / 96 / 144

40x40 L-1,55

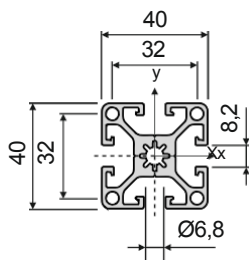
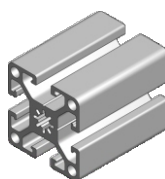

05.01035.00

$M = 1,53 \text{ kg/m}$
 $I_x = 8,40 \text{ cm}^4$
 $W_x = 4,20 \text{ cm}^3$
 $I_y = 8,40 \text{ cm}^4$
 $W_y = 4,20 \text{ cm}^3$

PE (m)
 6 / 48 / 96 / 144

40x40 L-1N

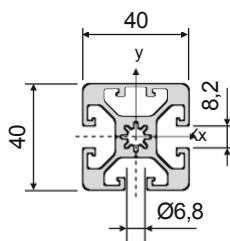
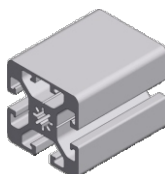

05.01130.00

$M = 1,56 \text{ kg/m}$
 $I_x = 8,73 \text{ cm}^4$
 $S_x = 4,36 \text{ cm}^3$
 $I_y = 8,41 \text{ cm}^4$
 $S_y = 4,21 \text{ cm}^3$

PE (m)
 6 / 48 / 96 / 144

40x40 L-2N90

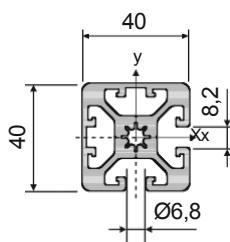
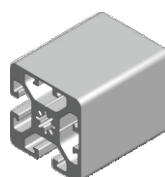

05.01131.00

$M = 1,59 \text{ kg/m}$
 $I_x = 8,74 \text{ cm}^4$
 $S_x = 4,37 \text{ cm}^3$
 $I_y = 8,73 \text{ cm}^4$
 $W_y = 4,36 \text{ cm}^3$

PE (m)
 6 / 48 / 96 / 144

40x40 L-2N180

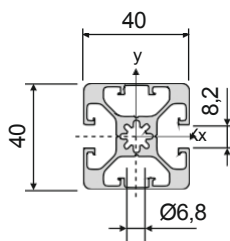
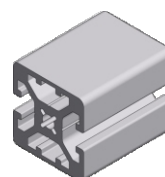

05.01132.00

$M = 1,59 \text{ kg/m}$
 $I_x = 9,06 \text{ cm}^4$
 $S_x = 4,53 \text{ cm}^3$
 $I_y = 8,42 \text{ cm}^4$
 $S_y = 4,21 \text{ cm}^3$

PE (m)
 6 / 48 / 96 / 144

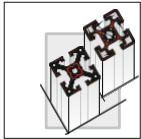

ALU-PROFILE PROFILY PROFILY



40x80 EL-2,45

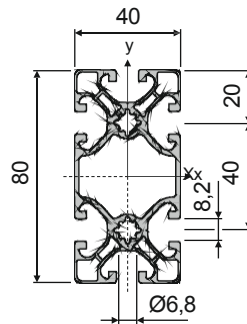
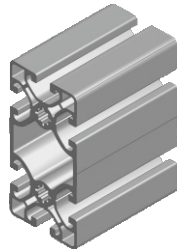

05.02164.00

M = 2,41 kg/m
 $I_x = 55,44 \text{ cm}^4$
 $\bar{S}_x = 13,80 \text{ cm}^3$
 $I_y = 14,90 \text{ cm}^4$
 $\bar{S}_y = 7,45 \text{ cm}^3$

PE (m)
 6 / 24 / 48 / 72

40x80 L-2,65

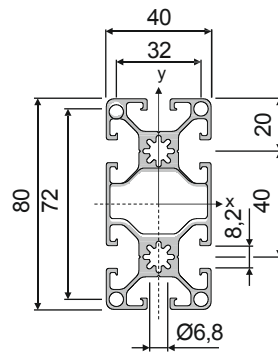
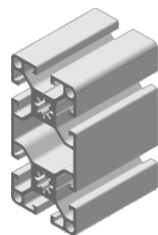

05.01036.00

M = 2,58 kg/m
 $I_x = 61,26 \text{ cm}^4$
 $\bar{S}_x = 15,32 \text{ cm}^3$
 $I_y = 14,87 \text{ cm}^4$
 $\bar{S}_y = 7,44 \text{ cm}^3$

PE (m)
 6 / 24 / 48 / 72

40x80 L-2N

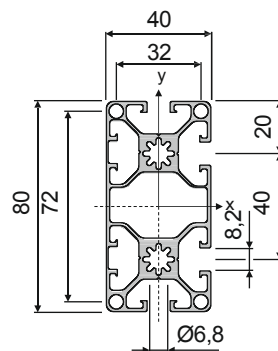
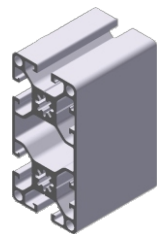

05.01037.00

M = 2,63 kg/m
 $I_x = 61,97 \text{ cm}^4$
 $\bar{S}_x = 15,49 \text{ cm}^3$
 $I_y = 15,52 \text{ cm}^4$
 $\bar{S}_y = 7,76 \text{ cm}^3$

PE (m)
 6 / 24 / 48 / 72

PROFILY
ALU-PROFIL
 PROFILY



40x80 L-3N

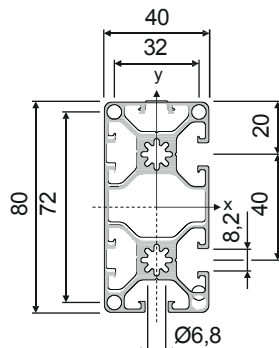
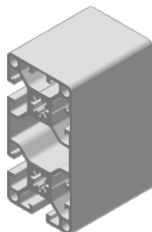

05.01038.00

M = 2,65 kg/m
 $I_x = 63,33 \text{ cm}^4$
 $S_x = 15,83 \text{ cm}^3$
 $I_y = 15,53 \text{ cm}^4$
 $S_y = 7,77 \text{ cm}^3$

PE (m)
 6 / 24 / 48 / 72



40x120 L

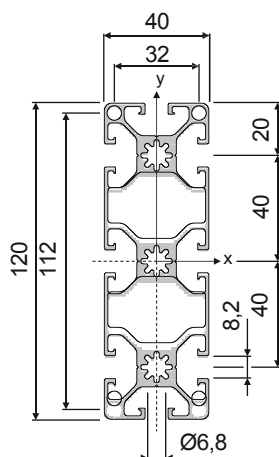
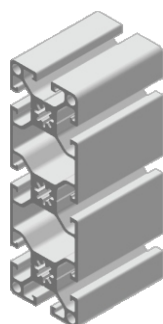

05.01046.00

M = 3,66 kg/m
 $I_x = 190,62 \text{ cm}^4$
 $S_x = 31,77 \text{ cm}^3$
 $I_y = 21,32 \text{ cm}^4$
 $S_y = 10,36 \text{ cm}^3$

PE (m)
 6 / 24 / 48 / 72

80x80 L

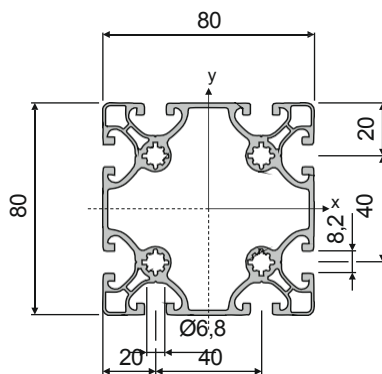
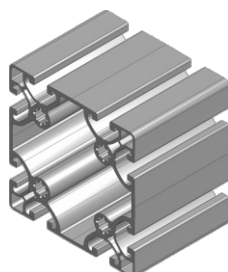

05.02165.00

M = 3,62 kg/m
 $I_x = 99,47 \text{ cm}^4$
 $S_x = 24,90 \text{ cm}^3$
 $I_y = 99,47 \text{ cm}^4$
 $S_y = 24,90 \text{ cm}^3$

PE (m)
 6 / 24 / 48 / 72

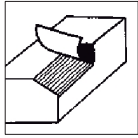

PROFILBEARBEITUNG

PROFILOVÉ DOKONČOVÁNÍ

USINAGE DE PROFILES



1x	2x	3x	4x
40x40	40x80	40x120	80x80
		05.xxxxx.09	
M8x40		05.xxxxx.10	M12x60
			05.xxxxx.12
M8x40		M8x40	05.xxxxx.11
			M12x60
			05.xxxxx.13

40x40	40x80	40x120	80x80
VSI 7		05.xxxxx.15 ■ 3,21	UNI
			05.xxxxx.40 ■ 3,11
VSI 7		VSI 7	05.xxxxx.16
			UNI
			05.xxxxx.41
BV14		05.xxxxx.25 ■ 3.06	VSA 14
			05.xxxxx.45 ■ 3,20
BV14		BV14	05.xxxxx.26
			VSA 14
			05.xxxxx.46
GV14		05.xxxxx.30 ■ 3.02	
GV14		GV14	05.xxxxx.31
AGV		05.xxxxx.35 ■ 3.04	
AGV		AGV	05.xxxxx.36

40x80

BV14V		05.xxxxx.85 ■ 3,06	UNI
			05.xxxxx.43 ■ 3,11
BV14V		BV14V	05.xxxxx.86
			UNI
			05.xxxxx.44
AGV		05.xxxxx.83 ■ 3.04	
AGV		AKV	05.xxxxx.84

Technické změny vyznačeny

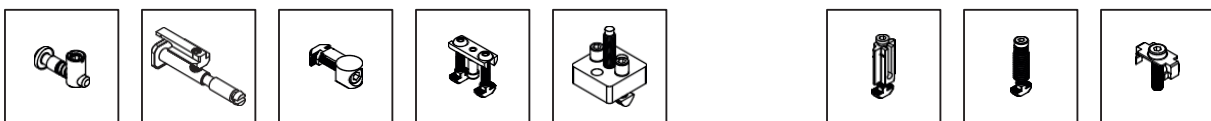



Konkavita

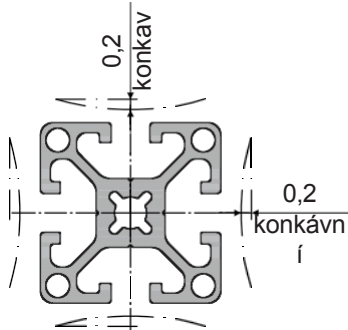

Matice

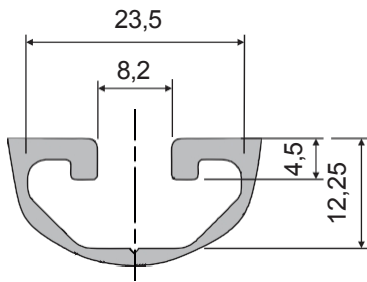

Kernloch

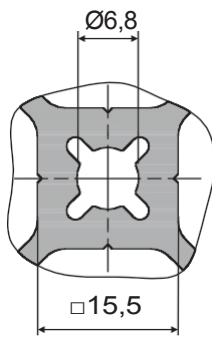

Vnější hrana

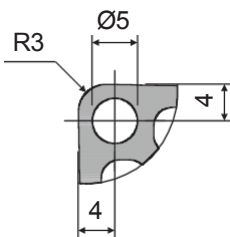

40x40N	40x40-1N	40x40-2N90	40x40-2N180
■ 2,31	■ 2,31	■ 2,31	■ 2,31
40x40N-45°	40x40N-R		
■ 2,32	■ 2,32		
40x80N	40x120N	40x160N	40x160N-4N
■ 2,32	■ 2,32	■ 2,33	■ 2,33
80x80N	80x80N-2N	80x80N-4N90	
■ 2,34	■ 2,34	■ 2,34	
80x120N	80x160N	40x40 KL	40x40 KL-180°
■ 2,35	■ 2,35	■ 2,37	■ 2,37
40R80-30°	40R80-45°	40R80-60°	40R80-90°
■ 2,36	■ 2,36	■ 2,36	■ 2,36

Technické změny vyhrazeny

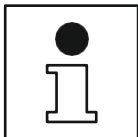

Průhyb profilů
 Průhyb profilů Flexion
 des profilés

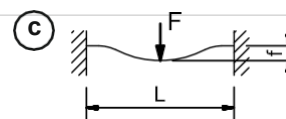
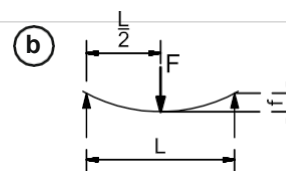
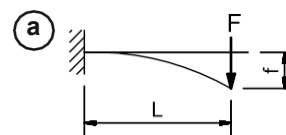
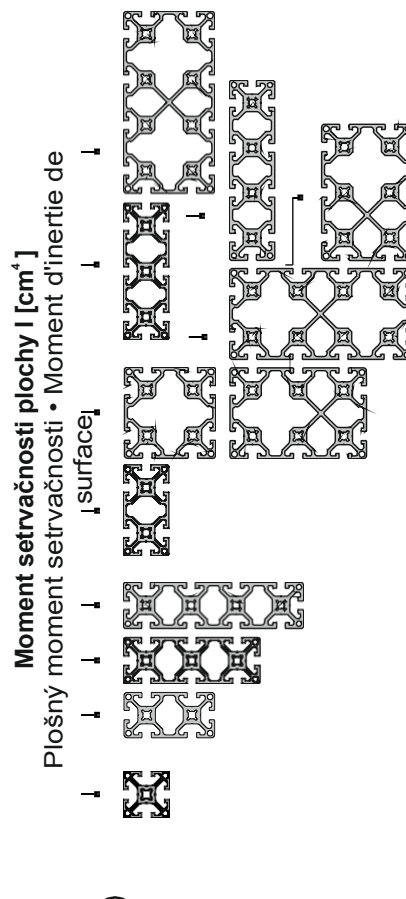
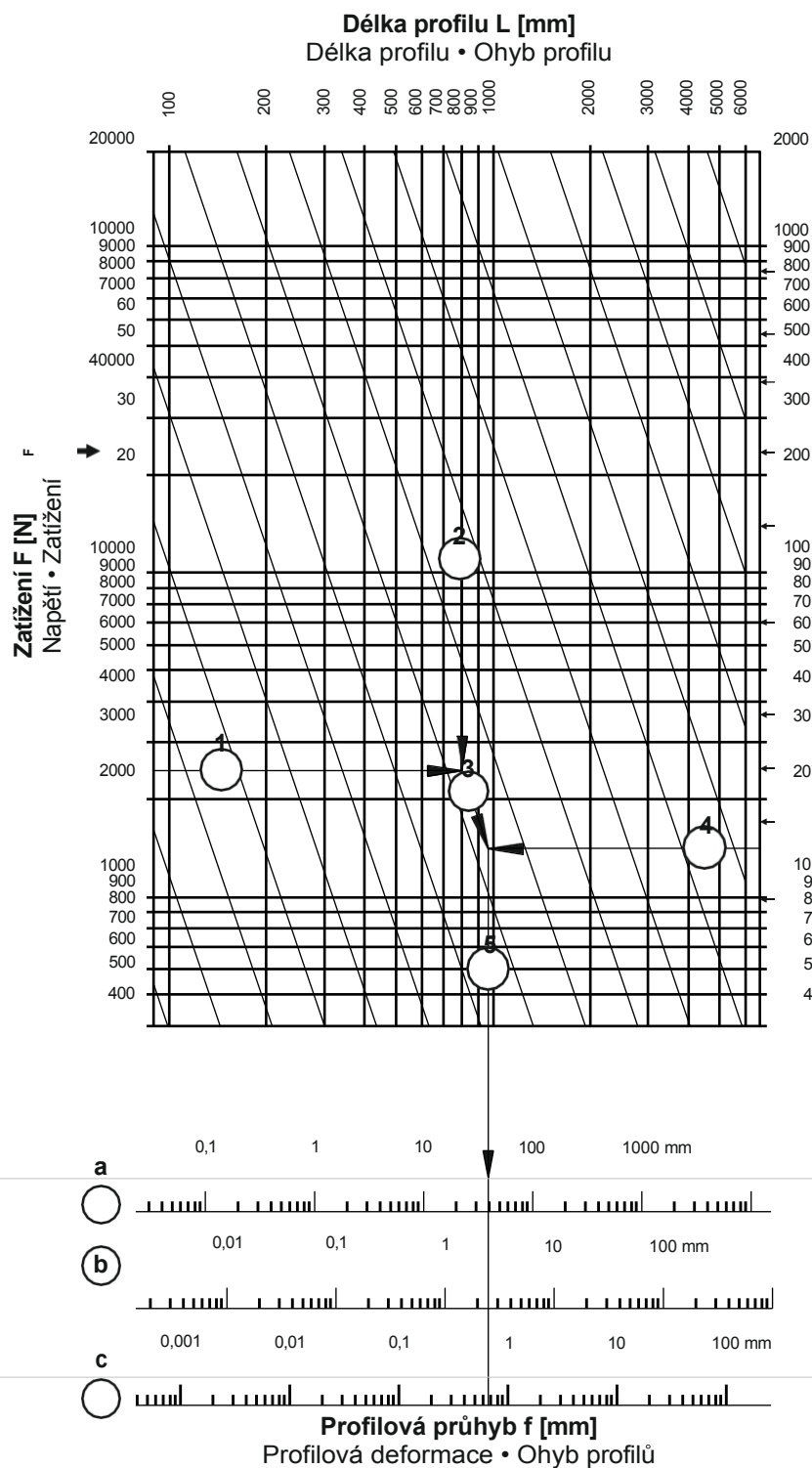

40x40 N

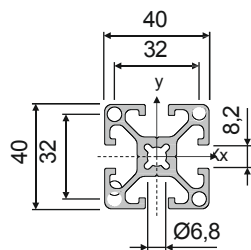
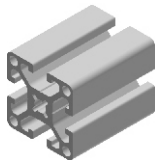

05.01002.00

$M = 1,72 \text{ kg/m}$
 $I_x = 9,66 \text{ cm}^4$ $W_x = 4,83 \text{ cm}^3$
 $I_y = 9,66 \text{ cm}^4$ $W_y = 4,83 \text{ cm}^3$

PE (m)
6 / 48 / 96 / 144

40x40 N-1N

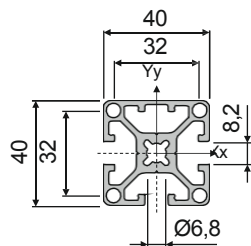
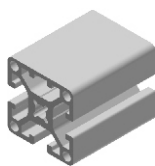

05.01026.00

$M = 1,75 \text{ kg/m}$
 $I_x = 10,06 \text{ cm}^4$ $S_x = 5,03 \text{ cm}^3$
 $I_y = 9,52 \text{ cm}^4$ $S_y = 4,76 \text{ cm}^3$

PE (m)
6 / 48 / 96 / 144

40x40 N-2N90

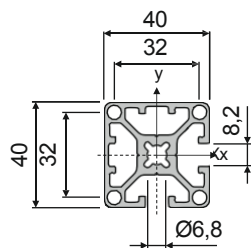
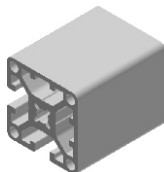

05.01027.00

$M = 1,79 \text{ kg/m}$
 $I_x = 10,07 \text{ cm}^4$ $W_x = 5,04 \text{ cm}^3$
 $I_y = 10,07 \text{ cm}^4$ $W_y = 5,04 \text{ cm}^3$

PE (m)
6 / 48 / 96 / 144

40x40 N-2N180

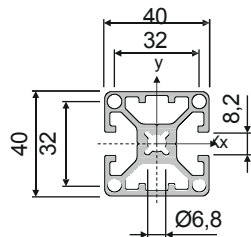
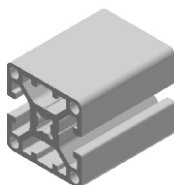

05.01028.00

$M = 1,79 \text{ kg/m}$
 $I_x = 10,61 \text{ cm}^4$ $S_x = 5,31 \text{ cm}^3$
 $I_y = 9,53 \text{ cm}^4$ $S_y = 4,77 \text{ cm}^3$

PE (m)
6 / 48 / 96 / 144

40x40 N-3N

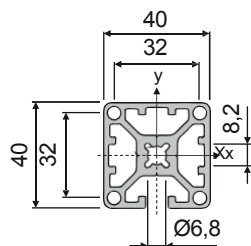
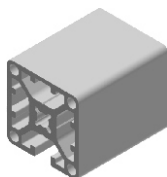

05.01536.00

$M = 1,83 \text{ kg/m}$
 $I_x = 10,62 \text{ cm}^4$ $S_x = 5,31 \text{ cm}^3$
 $I_y = 10,66 \text{ cm}^4$ $S_y = 5,33 \text{ cm}^3$

PE (m)
6 / 48 / 96 / 144

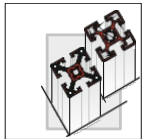

PROFILY
PROFILY
PROFILE ALU-

40

8

40x40 N-45°

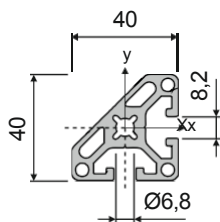
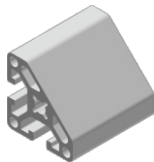

05.01029.00

M = 1,51 kg/m
 $I_x = 7,50 \text{ cm}^4$
 $W_x = 3,75 \text{ cm}^3$
 $I_y = 7,50 \text{ cm}^4$
 $W_y = 3,75 \text{ cm}^3$

PE (m)
 6 / 48 / 96 / 144

40x40 N-R

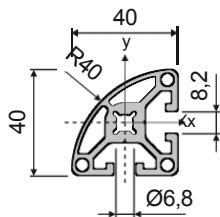
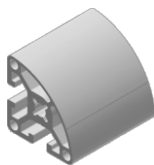

05.01943.00

M = 1,42 kg/m
 $I_x = 7,02 \text{ cm}^4$
 $S_x = 3,51 \text{ cm}^3$
 $I_y = 7,02 \text{ cm}^4$
 $S_y = 3,51 \text{ cm}^3$

PE (m)
 6 / 48 / 96 / 144

40x80 N

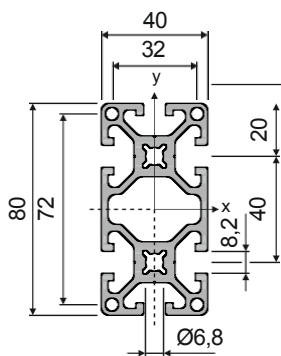
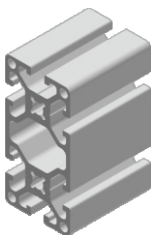

05.01003.00

M = 3,08 kg/m
 $I_x = 70,34 \text{ cm}^4$
 $W_x = 17,59 \text{ cm}^3$
 $I_y = 18,33 \text{ cm}^4$
 $W_y = 9,17 \text{ cm}^3$

PE (m)
 6 / 24 / 48 / 72

40x120 N

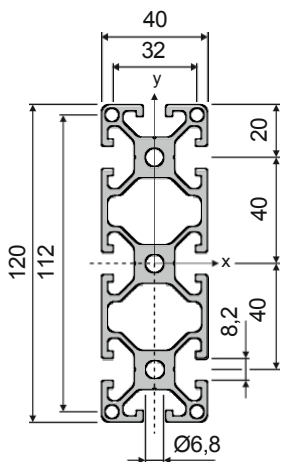
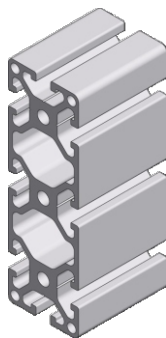

05.01047.00

M = 4,40 kg/m
 $I_x = 222,16 \text{ cm}^4$
 $W_x = 37,03 \text{ cm}^3$
 $I_y = 27,00 \text{ cm}^4$
 $W_y = 13,50 \text{ cm}^3$

PE (m)
 6 / 24 / 48 / 72

Technické změny vyhrazeny

40x160 N

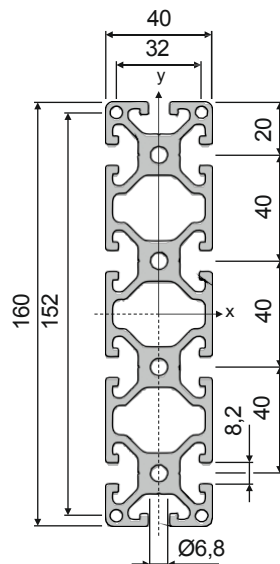
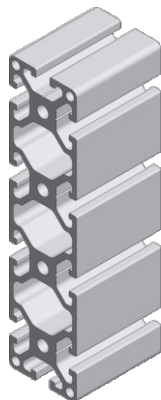

05.01820,00

M = 5,80 kg/m
 $I_x = 503,40 \text{ cm}^4$
 $S_x = 62,93 \text{ cm}^3$
 $I_y = 37,28 \text{ cm}^4$
 $S_y = 18,64 \text{ cm}^3$

PE (m)
 6 / 24 / 48 / 72

40x160 N-4N

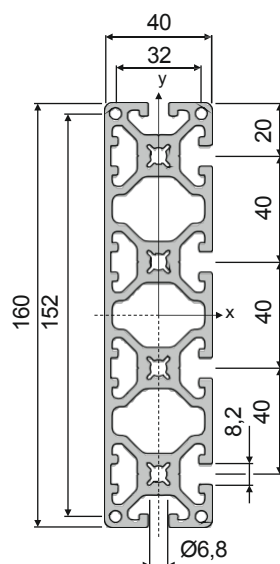
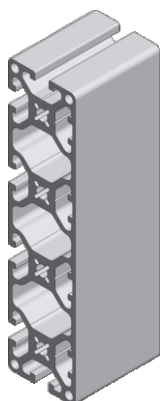

05.01819,00

M = 6,00 kg/m
 $I_x = 514,34 \text{ cm}^4$
 $S_x = 64,30 \text{ cm}^3$
 $I_y = 37,28 \text{ cm}^4$
 $S_y = 18,64 \text{ cm}^3$

PE (m)
 6 / 24 / 48 / 72

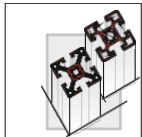

PROFILY
PROFILY
PROFILE ALU-

40

8

80x80 N

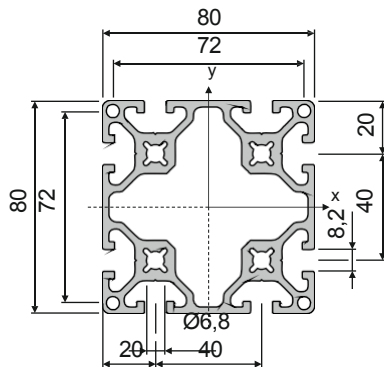
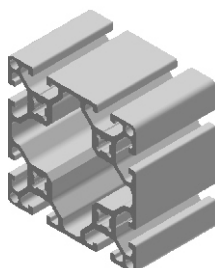

05.01004.00

M = 5,00 kg/m
I_x = 125,70 cm⁴
W_x = 31,42 cm³ I
S_x = 125,70 cm⁴
S_y = 31,42 cm³

PE (m)
6 / 24 / 48 / 72

80x80 N-2N

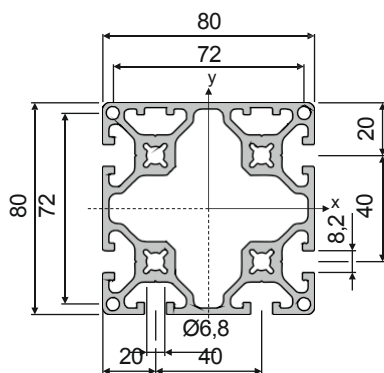
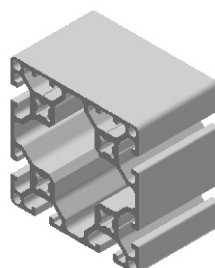

05.01931.00

M = 4,96 kg/m
I_x = 130,31 cm⁴
S_x = 32,58 cm³
I_y = 126,94 cm⁴ S
= 31,74 cm³

PE (m)
6 / 24 / 48 / 72

80x80 N-4N90

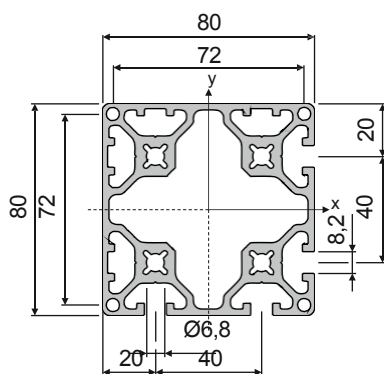
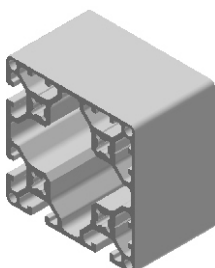

05.01932.00

M = 5,05 kg/m
I_x = 131,64 cm⁴
S_x = 32,91 cm³
I_y = 131,48 cm⁴ S
= 32,87 cm³

PE (m)
6 / 24 / 48 / 72

80x120 N

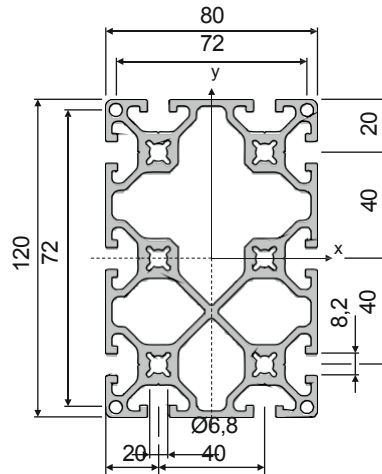
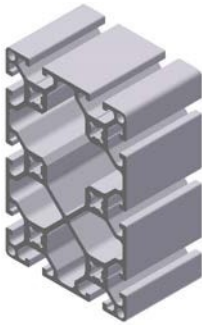

05.01823.00

$$\begin{aligned}
 &= 7,16 \text{ kg/m} \\
 I_x &= 384,71 \text{ cm}^4 \\
 S_x &= 64,14 \text{ cm}^3 \\
 I_y &= 182,71 \text{ cm}^4 \\
 S_y &= 45,68 \text{ cm}^3
 \end{aligned}$$

PE (m)
6 / 12 / 24 / 36

2

80x160 N

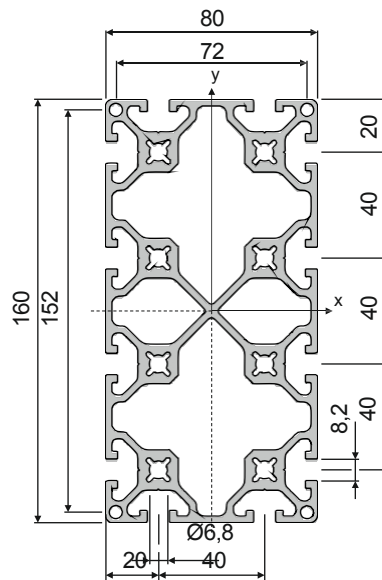
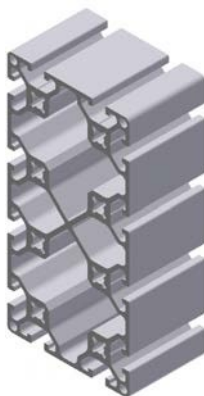

05.01824.00

$$\begin{aligned}
 M &= 8,86 \text{ kg/m} \\
 I_x &= 820,19 \text{ cm}^4 \\
 S_x &= 102,52 \text{ cm}^3 \\
 I_y &= 238,14 \text{ cm}^4 \\
 S_y &= 59,54 \text{ cm}^3
 \end{aligned}$$

PE (m)
6 / 12 / 24 / 36

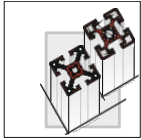

PROFILY PROFILY PROFILE ALU-

N
40

8

40R80 - 30°

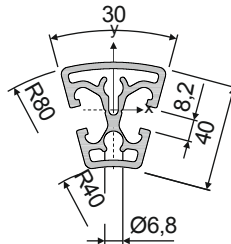
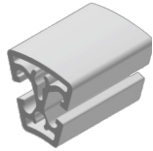

05.01866.00

$$\begin{aligned}
 M &= 1,62 \text{ kg/m} \\
 I_x &= 9,76 \text{ cm}^4 \quad W \\
 &= 4,80 \text{ cm}^3 \quad I \\
 &= 4,88 \text{ cm}^4 \quad W = \\
 &3,07 \text{ cm}^3
 \end{aligned}$$

PE (m)
6 / 48 / 96 / 144

40R80 - 45°

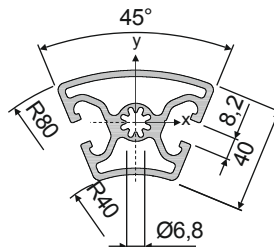
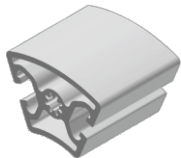

05.01867.00

$$\begin{aligned}
 &= 2,20 \text{ kg/m} \\
 I_x &= 12,50 \text{ cm}^4 \quad W \\
 &= 5,63 \text{ cm}^3 \quad I \\
 &= 19,36 \text{ cm}^4 \quad W = \\
 &6,53 \text{ cm}^3
 \end{aligned}$$

PE (m)
6 / 36 / 72 / 108

40R80 - 60°

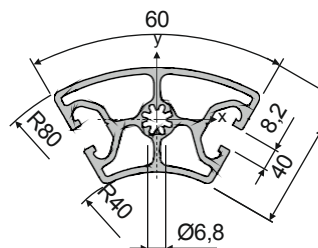
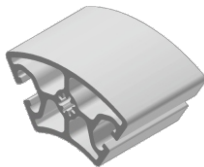

05.01868.00

$$\begin{aligned}
 M &= 2,78 \text{ kg/m} \\
 I_x &= 16,45 \text{ cm}^4 \quad W \\
 &= 6,76 \text{ cm}^3 \quad I \\
 &= 41,28 \text{ cm}^4 \quad W = \\
 &10,62 \text{ cm}^3
 \end{aligned}$$

PE (m)
6 / 24 / 48 / 72

40R80 - 90°

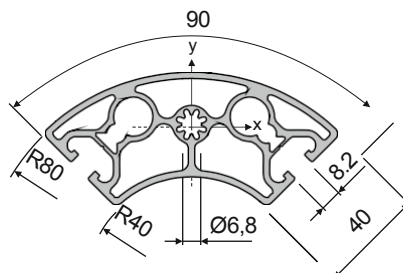

05.01869.00

$$\begin{aligned}
 M &= 3,92 \text{ kg/m} \quad I \\
 &= 25,70 \text{ cm}^4 \\
 W_x &= 9,51 \text{ cm}^3 \quad I \\
 &= 123,94 \text{ cm}^4 \quad W = \\
 &22,42 \text{ cm}^3
 \end{aligned}$$

PE (m)
6 / 18 / 36 / 54

40

8

40x40 KL

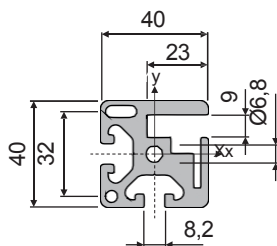

05.01940.00

M = 2,10 kg/m
I_x = 11,98 cm⁴
S_x = 5,99 cm³
I_y = 10,75 cm⁴
S_y = 5,38 cm³

PE (m)
6 / 48 / 96 / 144

Klemmleiste und Schrauben nicht im Lieferumfang enthalten
Upínací lišty a šrouby nejsou součástí dodávky
Baguette a šrouby nejsou součástí balení

2

40x40 KL-180°

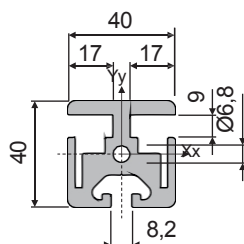

05.01942.00

M = 2,26 kg/m
I_x = 13,05 cm⁴
S_x = 6,53 cm³
I_y = 11,51 cm⁴
S_y = 5,76 cm³

PE (m)
6 / 48 / 96 / 144

Klemmleiste und Schrauben nicht im Lieferumfang enthalten
Upínací lišty a šrouby nejsou součástí dodávky
Baguette et vis ne sont pas inclus

Klemmleiste

Svorníky · Bageta

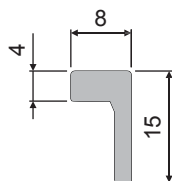

05.01922.00

PE (m)
6



99,00005,00

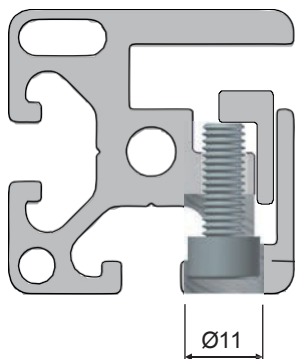

M6x16, DIN 7984
Objednávejte prosím
samostatně Objednávejte
prosím samostatně

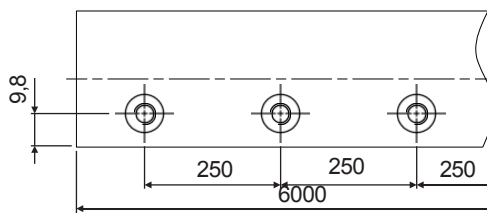

Otvory již jsou v profilu k dispozici Otvory
již jsou v profilech k dispozici Profilés déjà
usinés

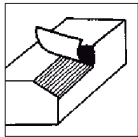

PROFILBEARBEITUNG

DOKONČOVÁNÍ PROFILŮ

USINAGE DE PROFILES



40x40	40x80	40x120	40x160	80x80	80x120	80x160	
	05.xxxxx.09						
M8x40		05.xxxxx.10		M12x60		05.xxxxx.12	
M8x40		M8x40	05.xxxxx.11	M12x60		M12x60	05.xxxxx.13

40x40	40x80	40x120	40x160	80x80	80x120	80x160			
VSI 7		05.xxxxx.15		■ 3,21	UNI		05.xxxxx.40	■ 3,11	
VSI 7		VSI 7	05.xxxxx.16		UNI		UNI	05.xxxxx.41	
BV14		05.xxxxx.25		■ 3,06	VSA 14		05.xxxxx.45		■ 3,20
BV14		BV14	05.xxxxx.26		VSA 14		VSA 14	05.xxxxx.46	
GV14		05.xxxxx.30		■ 3,02					
GV14		GV14	05.xxxxx.31						

40x80

BV14V		05.xxxxx.85	■ 3,06	UNI		05.xxxxx.43	■ 3,11	
BV14V		BV14V	05.xxxxx.86		UNI		UNI	05.xxxxx.44

Technické změny vyhrazeny

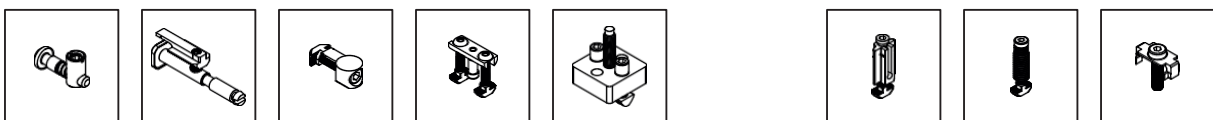

PROFILY ALU-PROFIL

PROFILY

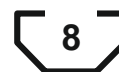

Konkávita

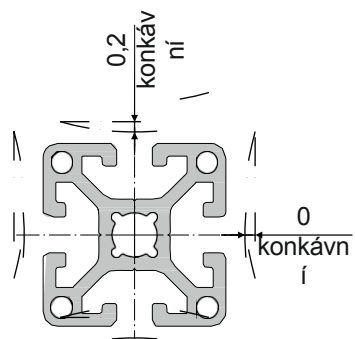

40x40 N-10K



■ 2,41

40x80 N-10K

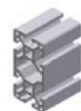

■ 2,41

Oře ch

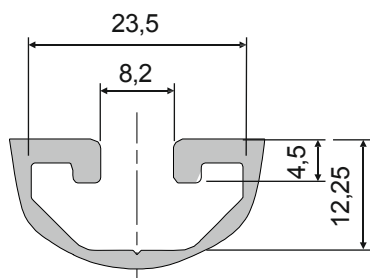

Kernloch

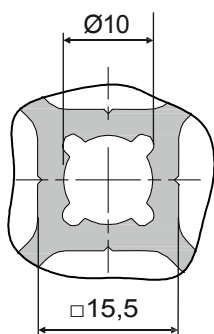

Vnější hrana

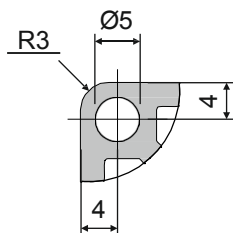

2

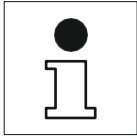

Průhyb profilů
 Průhyb profilů Flexion
 des profilés

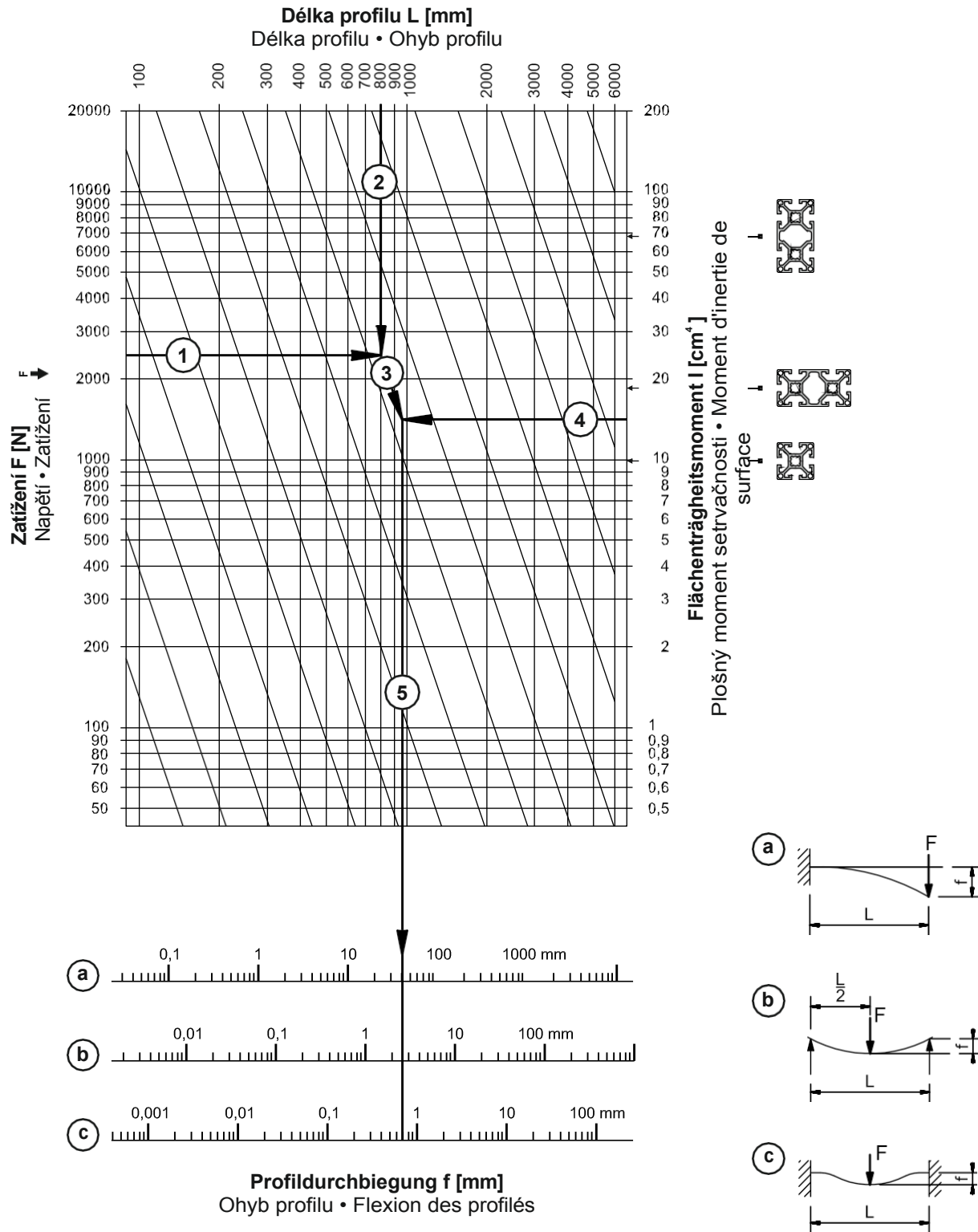

Technické změny vyhrazeny

PROFILY
ALU-PROFIL
 PROFILY



40x40 N-10K

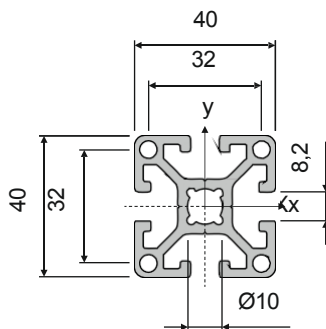
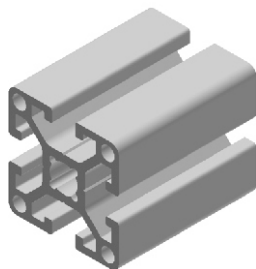

05.01133.00

= 1,60 kg/m
 $I_x = 9,46 \text{ cm}^4$
 $W_x = 4,73 \text{ cm}^3$
 $I_y = 9,46 \text{ cm}^4$
 $W_y = 4,73 \text{ cm}^3$

PE (m)
 6 / 48 / 96 / 144



40x80 N-10K

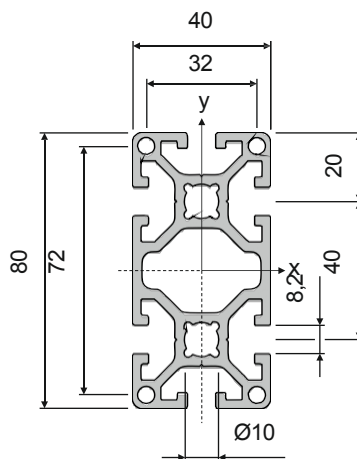
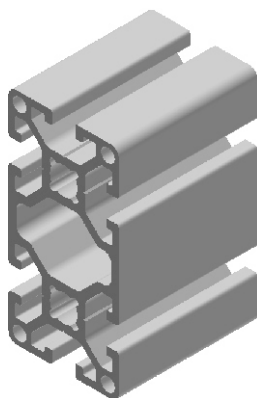

05.01134.00

$M = 3,00 \text{ kg/m l}$
 $I_x = 66,48 \text{ cm}^4$
 $S_x = 16,99 \text{ cm}^3 \text{ l}$
 $I_y = 18,41 \text{ cm}^4 \text{ S} =$
 $9,49 \text{ cm}^3$

PE (m)
 6 / 24 / 48 / 72

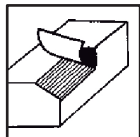

PROFILBEARBEITUNG

PROFILOVÉ DOKONČOVÁNÍ

USINAGE DE PROFILES



1x 2x

40x40-10K 40x80-10K



40x40-10K 40x80-10K



←

40x80



Technické změny vyhrazeny

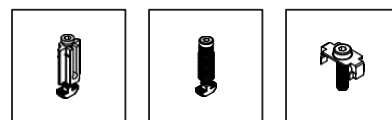
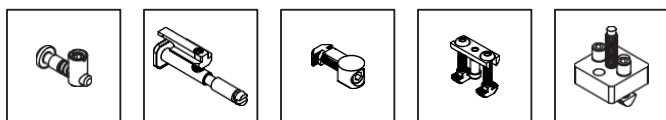

PROFILY ALU-PROFIL PROFILY

MS
40

8

Konkávnost

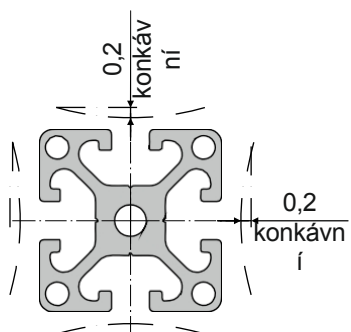

40x40MS



■ 2,45

40x80MS

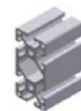

■ 2,45

80x80MS

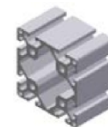

■ 2,45

Matice

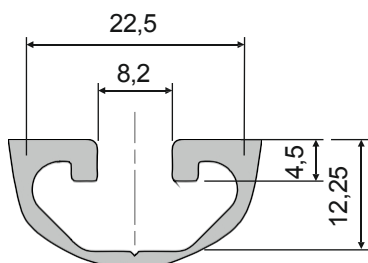

Kernloch

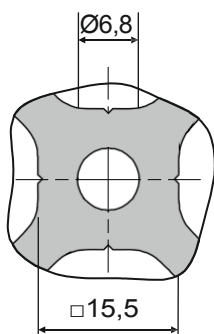

Vnější hrana

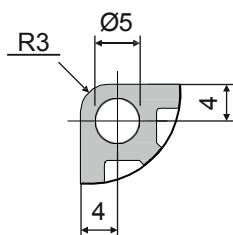

2

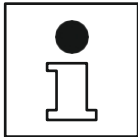

Průhyb profilů
 Průhyb profilů Flexion
 des profilés

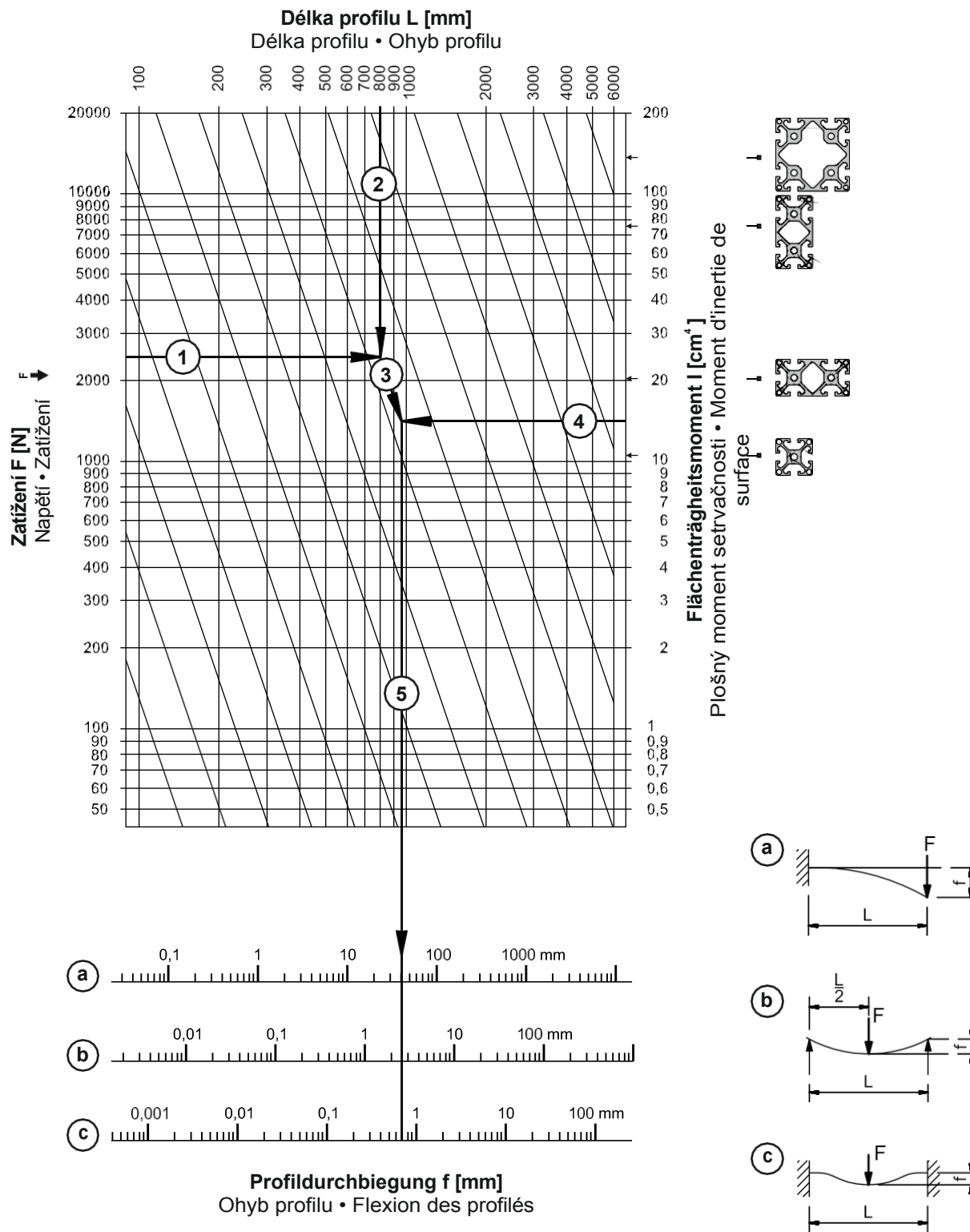

Technické změny vyznačeny

PROFILY
ALU-PROFIL
 PROFILY

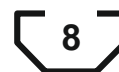

40x40 MS

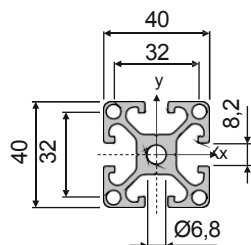
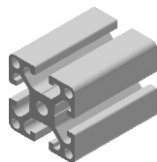

05.01114.00

M = 1,90 kg/m
 $I_x = 10,52 \text{ cm}^4$
 $\bar{S}_x = 5,26 \text{ cm}^3$
 $I_y = 10,52 \text{ cm}^4$
 $\bar{S}_y = 5,26 \text{ cm}^3$

PE (m)
 6 / 48 / 96 / 144



40x80 MS

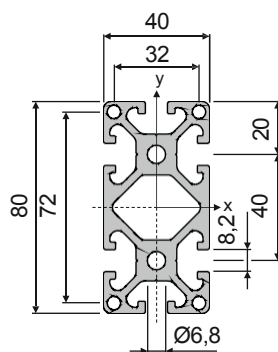
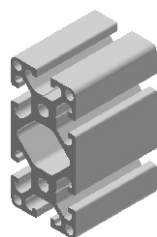

05.01115.00

M = 3,55 kg/m
 $I_x = 77,43 \text{ cm}^4$
 $\bar{S}_x = 18,98 \text{ cm}^3$
 $I_y = 21,34 \text{ cm}^4$
 $\bar{S}_y = 10,67 \text{ cm}^3$

PE (m)
 6 / 24 / 48 / 72

80x80 MS

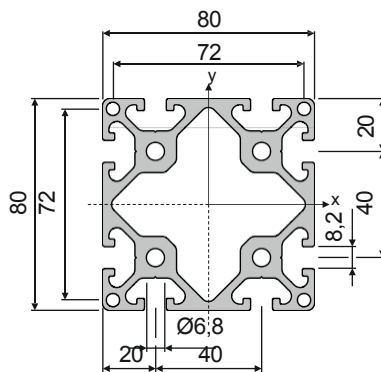
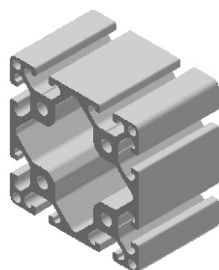

05.01116.00

M = 5,66 kg/m
 $I_x = 144,01 \text{ cm}^4$
 $\bar{S}_x = 36,00 \text{ cm}^3$
 $I_y = 144,01 \text{ cm}^4$
 $\bar{S}_y = 36,00 \text{ cm}^3$

PE (m)
 6 / 24 / 48 / 72

Technické změny vyhrazeny

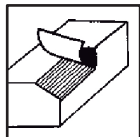

PROFILBEARBEITUNG

DOKONČOVÁNÍ PROFILŮ

USINAGE DE PROFILES

 40x40	 40x80	 80x80
--	--	--

	05.xxxxx.09
---	--------------------

M8x40 	05.xxxxx.10	M12x60 	05.xxxxx.12
---	--------------------	---	--------------------

M8x40  M8x40	05.xxxxx.11	M12x60  M12x60	05.xxxxx.13
---	--------------------	--	--------------------

 40x40	 40x80	 80x80
--	--	--

VSI 7 	05.xxxxx.15 ■ 3,21	UNI 	05.xxxxx.40 ■ 3,11
---	---------------------------	--	---------------------------

VSI 7  VSI 7	05.xxxxx.16	UNI  UNI	05.xxxxx.41
---	--------------------	--	--------------------

BV14 	05.xxxxx.25 ■ 3.06	VSA 14 	05.xxxxx.45 ■ 3,20
---	---------------------------	--	---------------------------

BV14  BV14	05.xxxxx.26	VSA 14  VSA 14	05.xxxxx.46
---	--------------------	--	--------------------

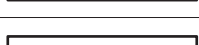
GV14 	05.xxxxx.30 ■ 3.02		
--	---------------------------	--	--

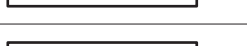
GV14  GV14	05.xxxxx.31		
---	--------------------	--	--

AGV 	05.xxxxx.35 ■ 3.04		
---	---------------------------	--	--

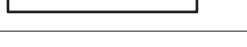
AGV  AGV	05.xxxxx.36		
---	--------------------	--	--

 40x80			
--	--	--	--

BV14V 	05.xxxxx.85 ■ 3,06	UNI 	05.xxxxx.43 ■ 3,11
---	---------------------------	--	---------------------------

BV14V  BV14V	05.xxxxx.86	UNI  UNI	05.xxxxx.44
---	--------------------	--	--------------------

AGV 	05.xxxxx.83 ■ 3.04		
---	---------------------------	--	--

AGV  AKV	05.xxxxx.84		
---	--------------------	--	--

Technické změny vyznačeny

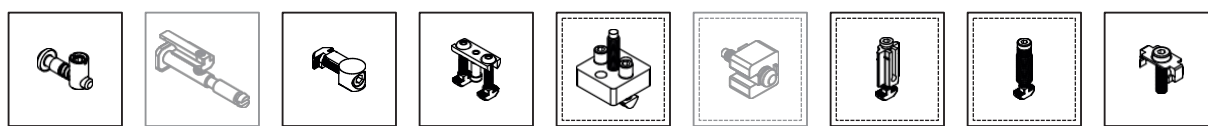

PROFILY ALU-PROFIL PROFILY



Konkávita

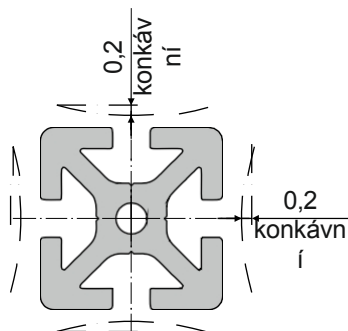

Matice

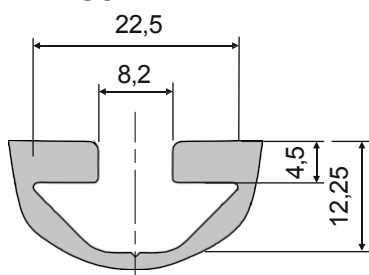

Kernloch

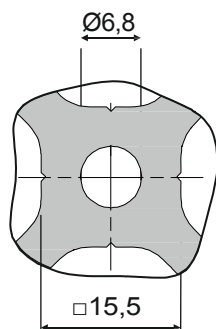

Vnější hrana

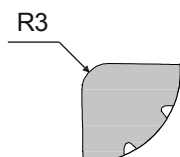

40x40S	40x80S	40x120S	40x160S
■ 2,49	■ 2,49	■ 2,49	■ 2,50
80x80S	80x120S	80x160S	
■ 2,50	■ 2,51	■ 2,51	
120x120S	120x160S		
■ 2,52	■ 2,52		

2

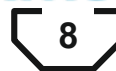
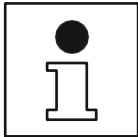

Průhyb profilů
 Průhyb profilů Flexion
 des profilés

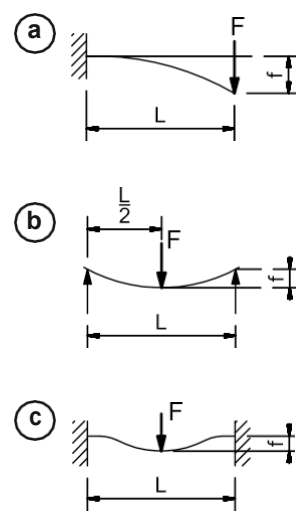
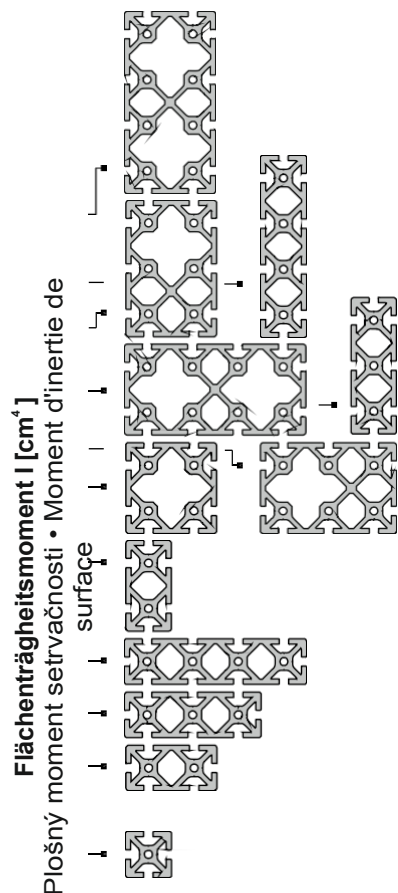
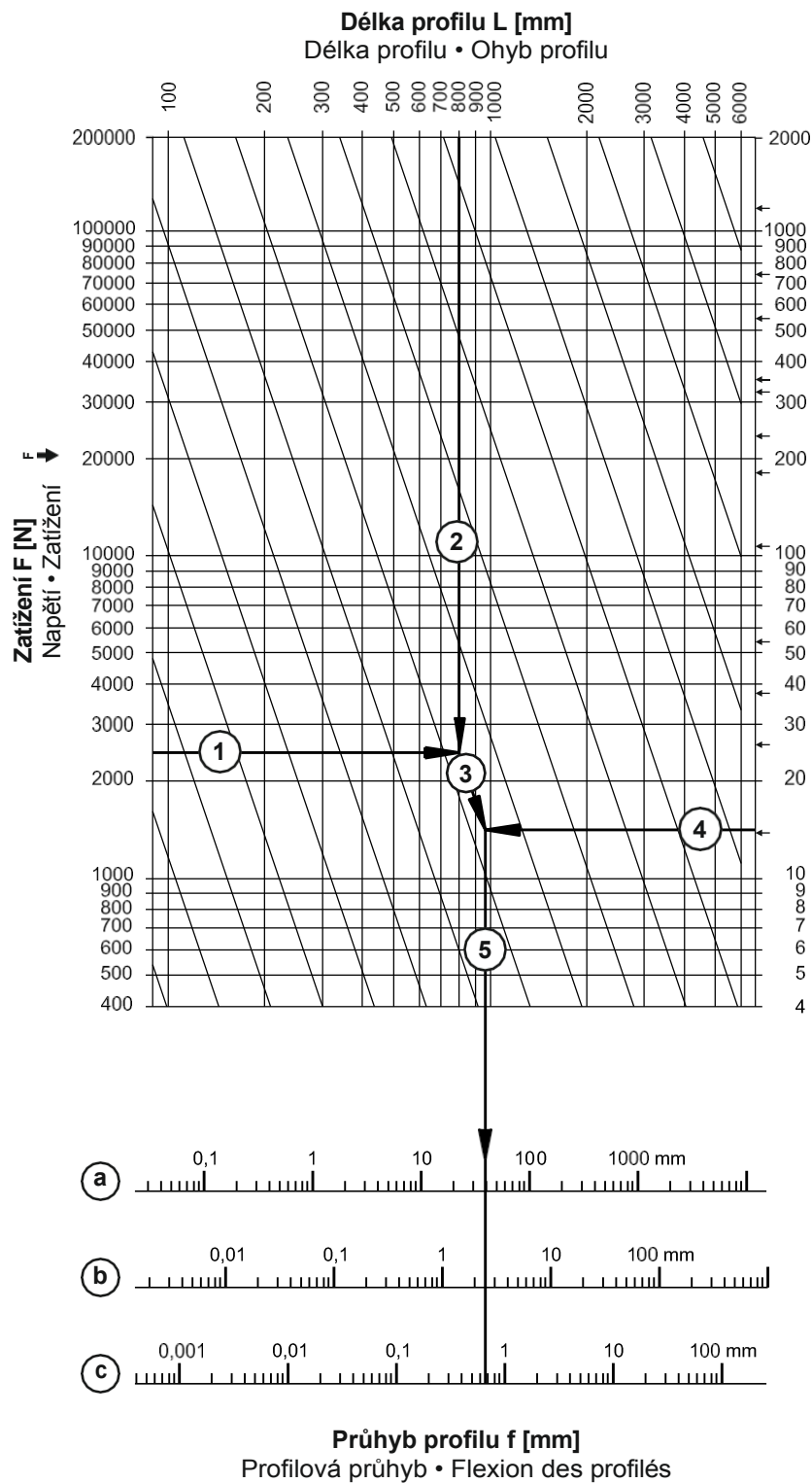

Technické změny vyznačeny

PROFILY
ALU-PROFIL
 PROFILY



40x40 S

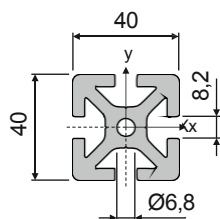
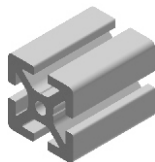

05.01005.00

M = 2,45 kg/m
 $I_x = 13,90 \text{ cm}^4$
 $\check{S}_x = 6,95 \text{ cm}^3$
 $I_y = 13,90 \text{ cm}^4$
 $\check{S}_y = 6,95 \text{ cm}^3$

PE (m)
 6 / 48 / 96 / 144



40x80 S

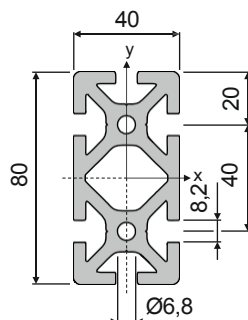
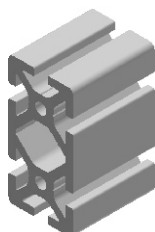

05.01006.00

M = 4,38 kg/m
 $I_x = 99,52 \text{ cm}^4$
 $\check{S}_x = 24,88 \text{ cm}^3$
 $I_y = 26,31 \text{ cm}^4$
 $\check{S}_y = 13,16 \text{ cm}^3$

PE (m)
 6 / 24 / 48 / 72

40x120 S

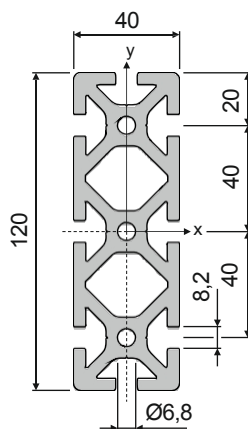
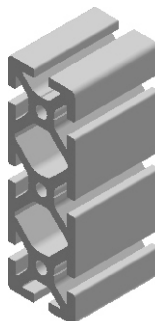

05.01008.00

M = 6,33 kg/m
 $I_x = 314,79 \text{ cm}^4$
 $W_x = 153,17 \text{ cm}^3$
 $I_y = 38,73 \text{ cm}^4$
 $\check{S}_y = 19,80 \text{ cm}^3$

PE (m)
 6 / 24 / 48 / 72

Technické změny vyhrazují

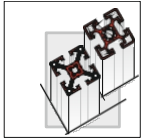

PROFILY
PROFILY
PROFILE ALU-

S
40



40x160 S

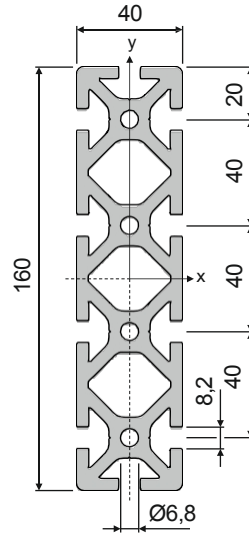
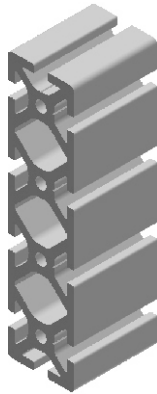

05.01814.00

M = 8,28 kg/m
 $I_x = 717,64 \text{ cm}^4$
 $S_x = 89,71 \text{ cm}^3$
 $I_y = 51,14 \text{ cm}^4$
 $S_y = 25,14 \text{ cm}^3$

PE (m)
 6 / 24 / 48 / 72

80x80 S

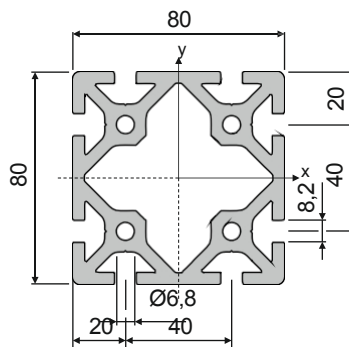
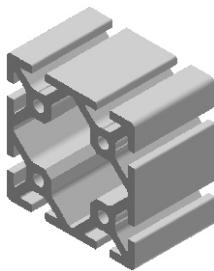

05.01007.00

M = 6,88 kg/m
 $I_x = 179,43 \text{ cm}^4$
 $S_x = 44,86 \text{ cm}^3$
 $I_y = 179,43 \text{ cm}^4$
 $S_y = 44,86 \text{ cm}^3$

PE (m)
 6 / 24 / 48 / 72

PROFILY
ALU-PROFIL
 PROFILY



80x120 S

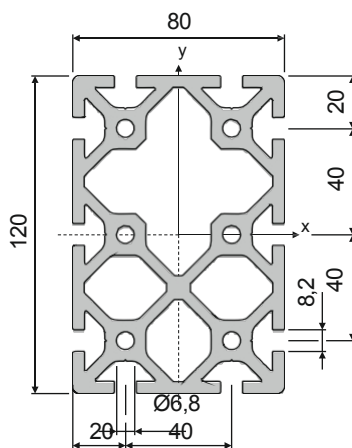
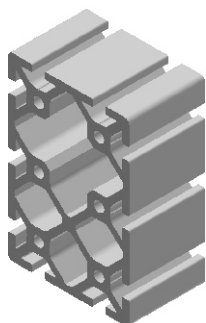

05.01817.00

$\rho = 9,85 \text{ kg/m}$
 $I_x = 537,80 \text{ cm}^4$
 $S_x = 89,63 \text{ cm}^3$
 $I_y = 255,13 \text{ cm}^4$
 $S_y = 63,78 \text{ cm}^3$

PE (m)
 6 / 12 / 24 / 36

2

80x160 S

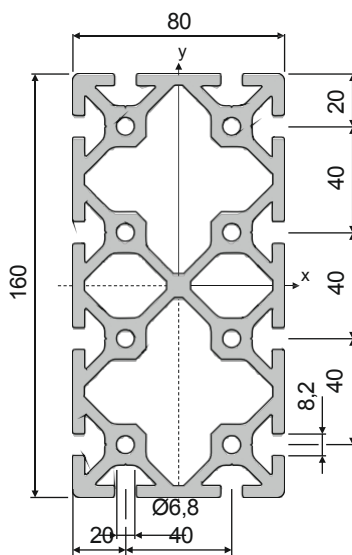
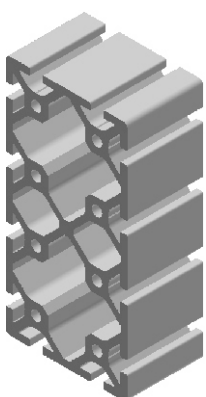

05.01818.00

$M = 12,18 \text{ kg/m}$
 $I_x = 1139,68 \text{ cm}^4$
 $S_x = 142,46 \text{ cm}^3$
 $I_y = 331,86 \text{ cm}^4$
 $S_y = 82,97 \text{ cm}^3$

PE (m)
 6 / 12 / 24 / 36

Technische Änderungen vorbehalten

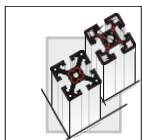

PROFILY
PROFILY
PROFILE ALU-

S
40



120x120 S

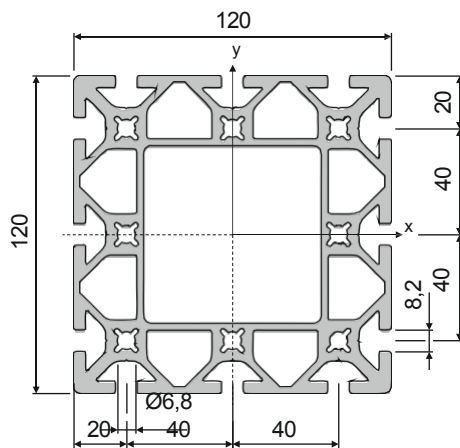
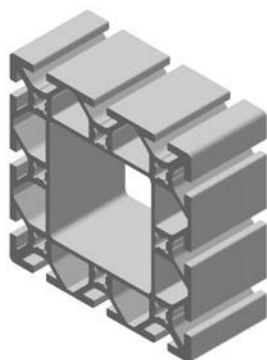

05.01709.00

M = 11,13 kg/m
I_x = 691,97 cm⁴
S_x = 115,33 cm³
I_y = 691,97 cm⁴ W
= 115,33 cm³

PE (m)
6 / 12 / 24 / 36

120x160 S

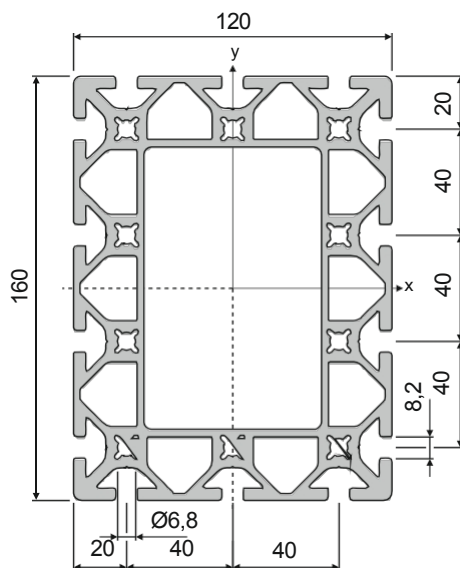
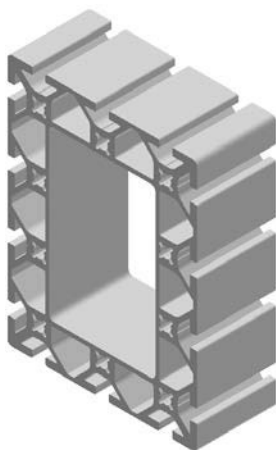

05.01710.00

M = 13,48 kg/m
I_x = 1490,66 cm⁴
S_x = 186,33 cm³
I_y = 883,09 cm⁴
S_y = 147,18 cm³

PE (m)
6 / 12 / 24 / 36

Y
POZNÁMK
Y
POZNÁMK
Y

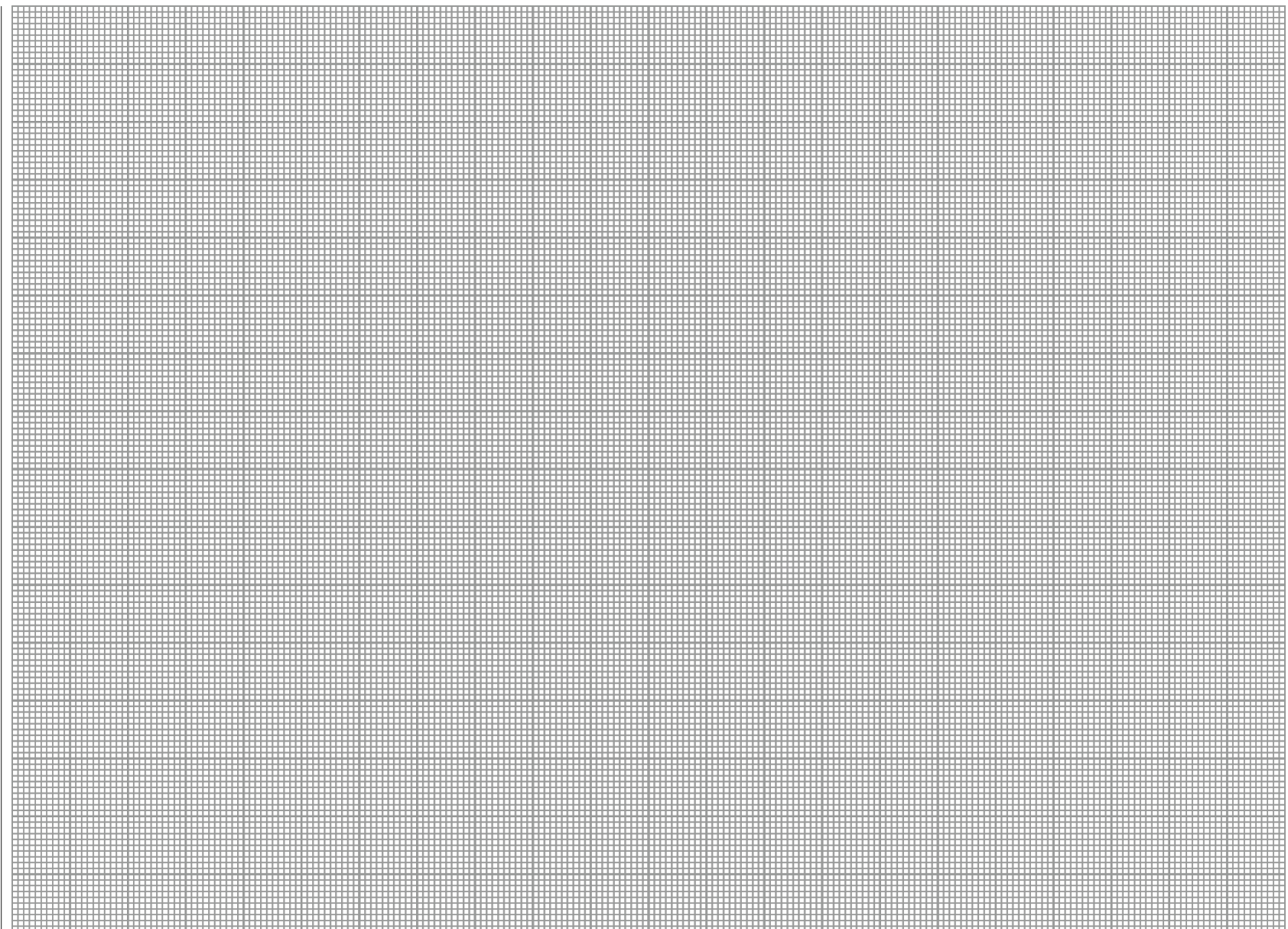

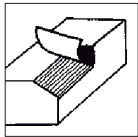

PROFILBEARBEITUNG DOKONČOVÁNÍ PROFILŮ USINAGE DE PROFILES



40x40	40x80	40x120	40x160	80x80	80x120	80x160			
	05.xxxxx.09								
M8x40		05.xxxxx.10		M12x60		05.xxxxx.12			
M8x40		M8x40	05.xxxxx.11		M12x60		M12x60	05.xxxxx.13	

40x40	40x80	40x120	40x160	80x80	80x120	80x160			
VSI 7		05.xxxxx.15		■ 3,21	UNI		05.xxxxx.40		■ 3,11
VSI 7		VSI 7	05.xxxxx.16		UNI		UNI	05.xxxxx.41	
BV14		05.xxxxx.25		■ 3.06	VSA 14		05.xxxxx.45		■ 3,20
BV14		BV14	05.xxxxx.26		VSA 14		VSA 14	05.xxxxx.46	
GV14		05.xxxxx.30		■ 3.02					
GV14		GV14	05.xxxxx.31						
AGV		05.xxxxx.35		■ 3.04					
AGV		AGV	05.xxxxx.36						

40x80

BV14V		05.xxxxx.85		■ 3,06	UNI		05.xxxxx.43		■ 3,11
BV14V		BV14V	05.xxxxx.86		UNI		UNI	05.xxxxx.44	
AGV		05.xxxxx.83		■ 3.04					
AGV		AKV	05.xxxxx.84						

Technické změny vyhrazeny

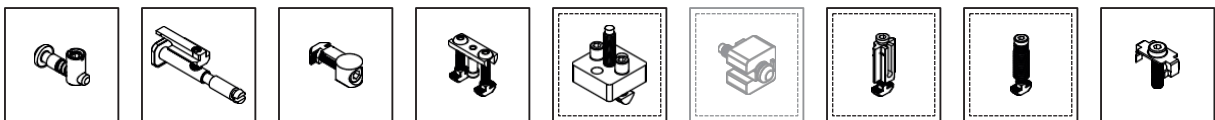

Konkávita

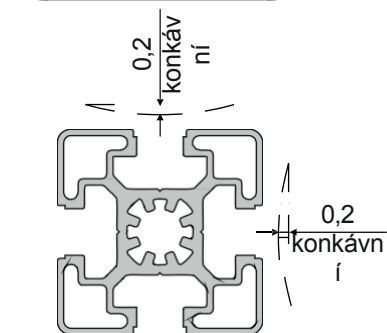

Mat ice

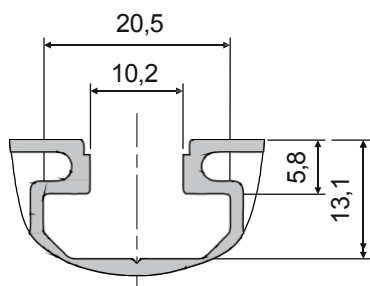

Kernloch

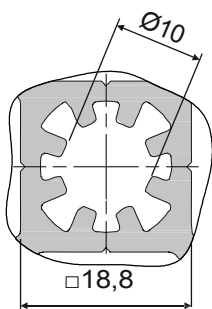

Vnější hrana

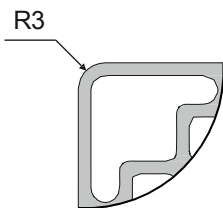

45x45EL-1,4



■ 2,57

45x45L-1,6



■ 2,57

45x45L-1N



■ 2,57

45x45L-2N90



■ 2,57

45x45L-2N180



■ 2,57

45x45L-3N



■ 2,57

45x45L-R



■ 2,58

45x60L



■ 2,58

45x90EL-2,9

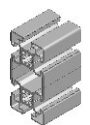

■ 2,58

60x60L

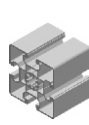

■ 2,59

45x180L

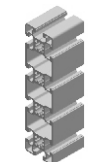

■ 2,59

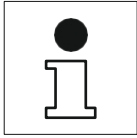

Průhyb profilů
 Průhyb profilů Flexion
 des profilés

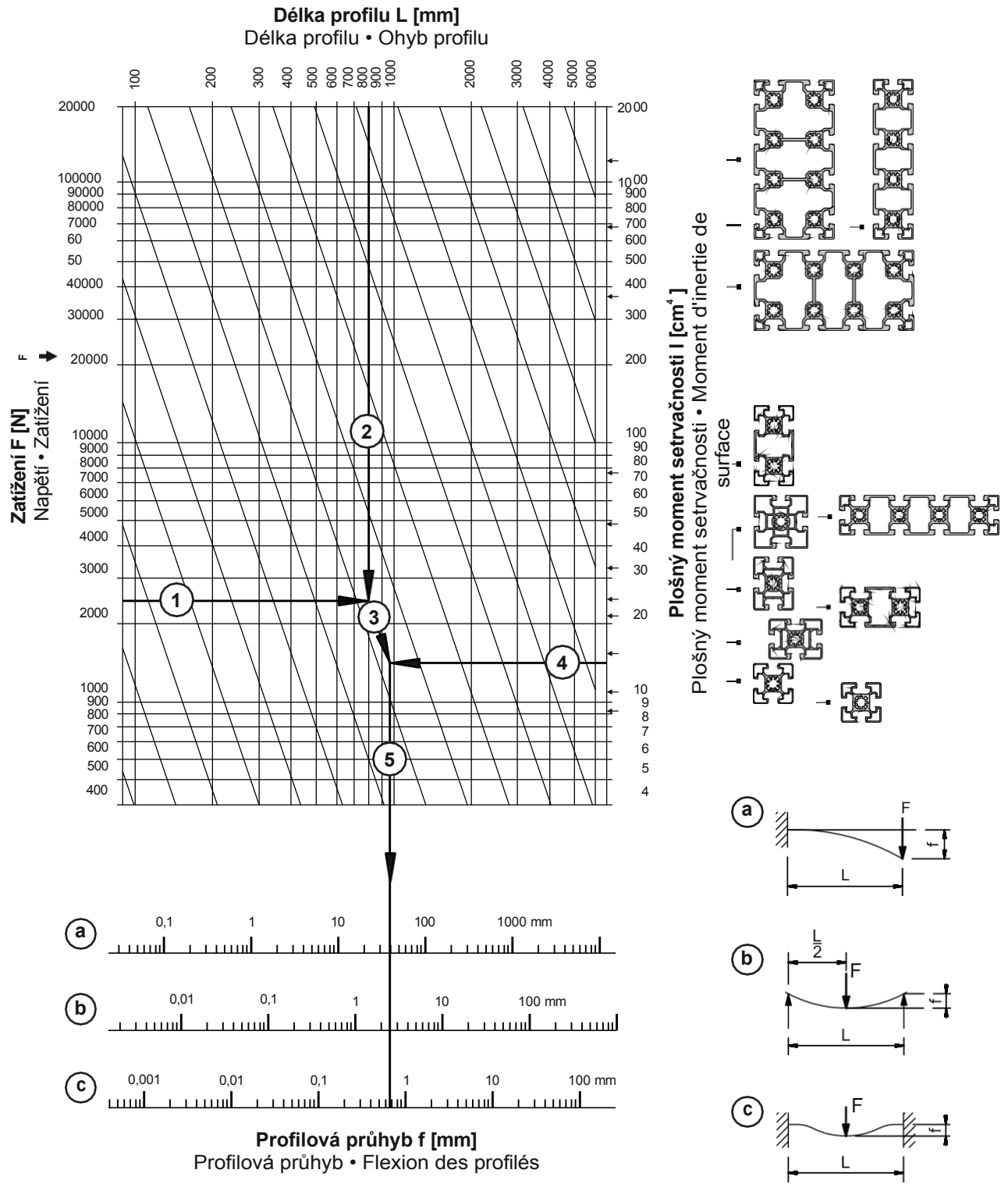

Technické změny vyznačeny

PROFILY
ALU-PROFIL
 PROFILY



45x45 EL-1.4

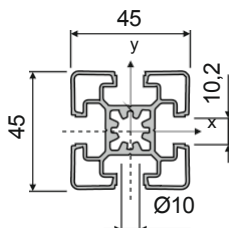
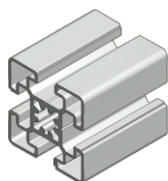

05.01517.00

M = 1,40 kg/m
 $I_x = 9,28 \text{ cm}^4$
 $W_x = 4,12 \text{ cm}^3$ |
 $I_y = 9,28 \text{ cm}^4$ | $W_y = 4,12 \text{ cm}^3$

PE (m)
 6 / 48 / 96 / 144

45x45 L-1,6

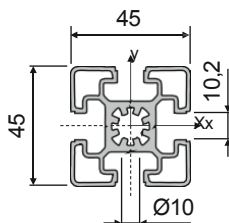
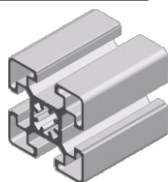

05.01041.00

M = 1,60 kg/m
 $I_x = 10,17 \text{ cm}^4$
 $S_x = 4,52 \text{ cm}^3$
 $I_y = 10,17 \text{ cm}^4$ | $S_y = 4,52 \text{ cm}^3$

PE (m)
 6 / 48 / 96 / 144

45x45 L-1N

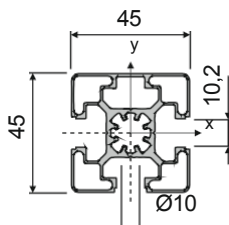
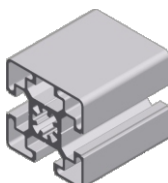

05.01900.00

M = 1,65 kg/m
 $I_x = 10,95 \text{ cm}^4$
 $S_x = 4,87 \text{ cm}^3$
 $I_y = 10,19 \text{ cm}^4$ | $S_y = 4,53 \text{ cm}^3$

PE (m)
 6 / 48 / 96 / 144

45x45 L-2N90

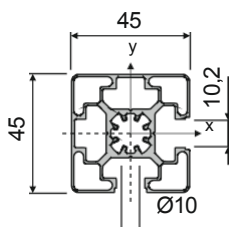
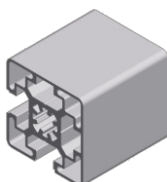

05.01901.00

M = 1,69 kg/m
 $I_x = 10,97 \text{ cm}^4$
 $S_x = 4,88 \text{ cm}^3$
 $I_y = 10,97 \text{ cm}^4$ | $S_y = 4,88 \text{ cm}^3$

PE (m)
 6 / 48 / 96 / 144

45x45 L-2N180

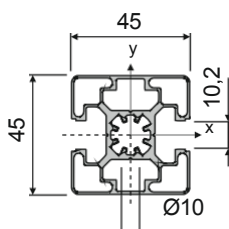
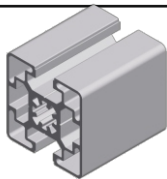

05.01902.00

M = 1,69 kg/m
 $I_x = 11,73 \text{ cm}^4$
 $S_x = 4,88 \text{ cm}^3$
 $I_y = 10,21 \text{ cm}^4$ | $S_y = 4,88 \text{ cm}^3$

PE (m)
 6 / 48 / 96 / 144

45x45 L-3N

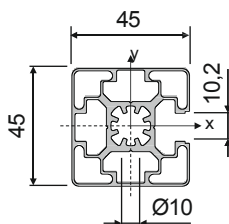
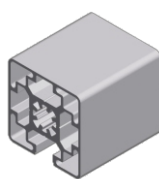

05.01903.00

M = 1,74 kg/m
 $I_x = 11,75 \text{ cm}^4$
 $S_x = 4,88 \text{ cm}^3$
 $I_y = 10,97 \text{ cm}^4$ | $S_y = 4,88 \text{ cm}^3$

PE (m)
 6 / 48 / 96 / 144

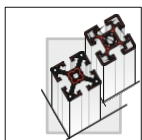

ALU-PROFILE
PROFILY
PROFILY



45x45 L-R

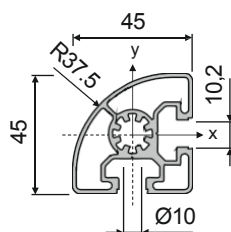
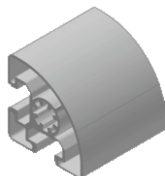

05.01904.00

M = 1,32 kg/m
I_x = 8,19 cm⁴
S_x = 3,64 cm³
I_y = 8,19 cm⁴ S_y
= 3,64 cm³

PE (m)
6 / 48 / 96 / 144

45x60 L

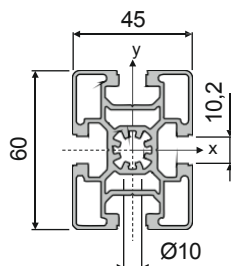
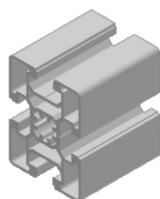

05.01043.00

= 2,19 kg/m
I_x = 25,14 cm⁴
S_x = 8,38 cm³ I_y =
14,73 cm⁴
S_y = 6,55 cm³

PE (m)
6 / 24 / 48 / 72

45x90 L-2,9

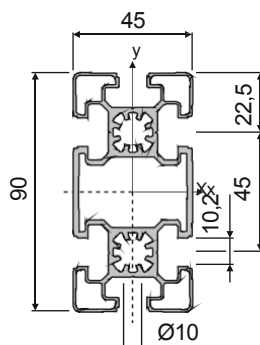
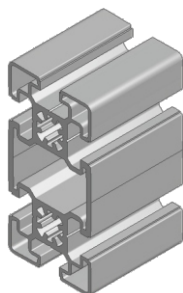

05.01518.00

M = 2,94 kg/m
I_x = 78,52 cm⁴
W_x = 17,45 cm³
I_y = 21,48 cm⁴ S_y
= 9,55 cm³

PE (m)
6 / 24 / 48 / 72

PROFILY
ALU-PROFIL
 PROFILY



60x60 L

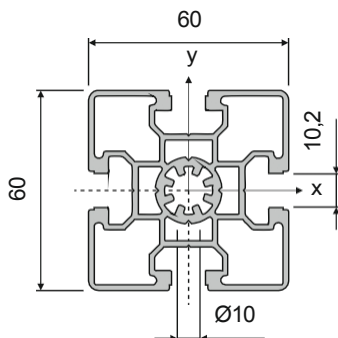
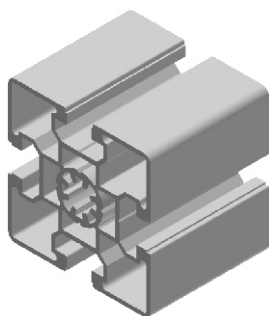

05.01012.00

M = 2,58 kg/m
 $I_x = 30,01 \text{ cm}^4$
 $W_x = 10,01 \text{ cm}^3$ |
 $I_y = 30,01 \text{ cm}^4$
 $W_y = 10,01 \text{ cm}^3$

PE (m)
 6 / 18 / 36 / 72



45x180 L

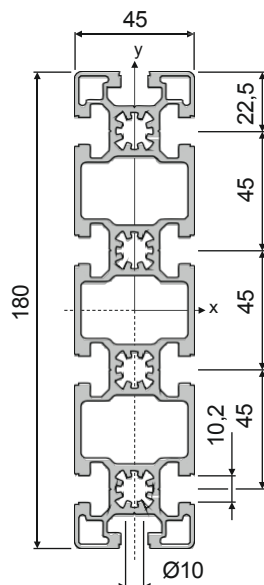
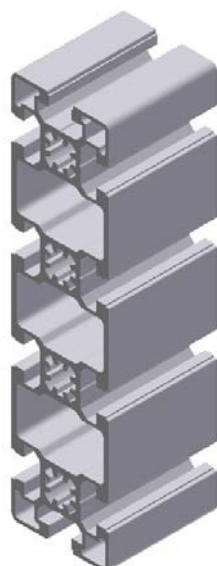

05.01044.00

M = 6,24 kg/m
 $I_x = 686,62 \text{ cm}^4$ | W
 $= 76,14 \text{ cm}^3$ |
 $I_y = 49,57 \text{ cm}^4$ | W
 $= 22,01 \text{ cm}^3$

PE (m)
 6 / 12 / 24 / 36

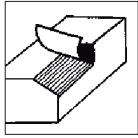

PROFILBEARBEITUNG

PROFILOVÉ DOKONČOVÁNÍ

USINAGE DE PROFILES

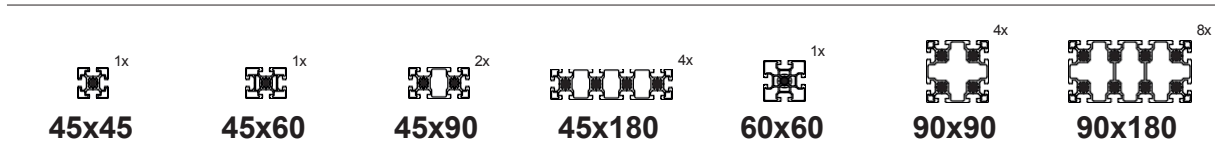

		05.xxxxx.09				
M12x60		05.xxxxx.10		M16x115		05.xxxxx.12
M12x60		05.xxxxx.11		M16x115		05.xxxxx.13

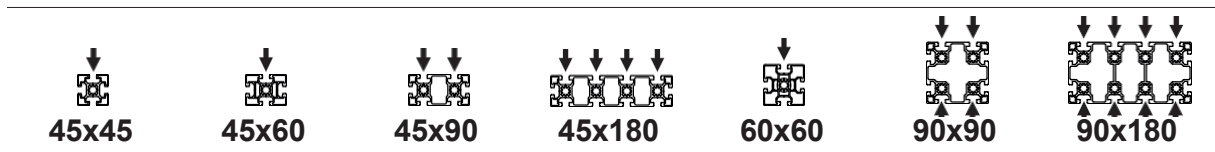

VSI 9,5		05.xxxxx.15	■ 3,21	AGV		05.xxxxx.35	■ 3,04
VSI 9,5		05.xxxxx.16		AGV		05.xxxxx.36	
BV17		05.xxxxx.25	■ 3,06	UNI		05.xxxxx.40	■ 3,11
BV17		05.xxxxx.26		UNI		05.xxxxx.41	
GV16		05.xxxxx.30	■ 3,02	VSA 20		05.xxxxx.45	■ 3,20
GV16		05.xxxxx.31		VSA 20		05.xxxxx.46	

BV17V		05.xxxxx.85	■ 3,06	UNI		05.xxxxx.43	■ 3,11
BV17V		05.xxxxx.86		UNI		05.xxxxx.44	

Technické změny vyhrazeny

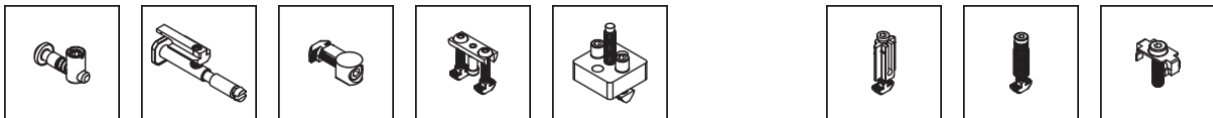

PROFILY PROFILY PROFILE ALU-

N
45

10

Konkávita

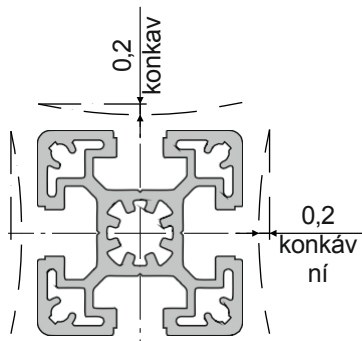

45x45N-1.9



■ 2,63

45x60N-2,85



■ 2,63

45x90N-3,4

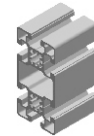

■ 2,63

90x90N

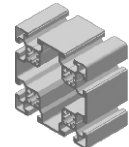

■ 2,63

2

Matice

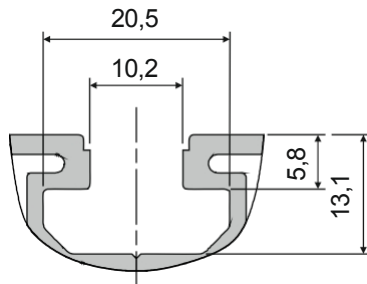

Kernloch

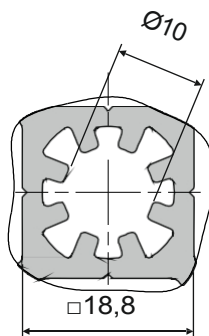

Vnější hrana

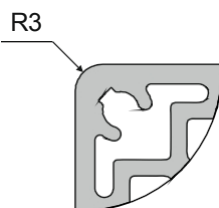

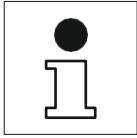

Průhyb profilů
 Průhyb profilů Průhyb
 profilů

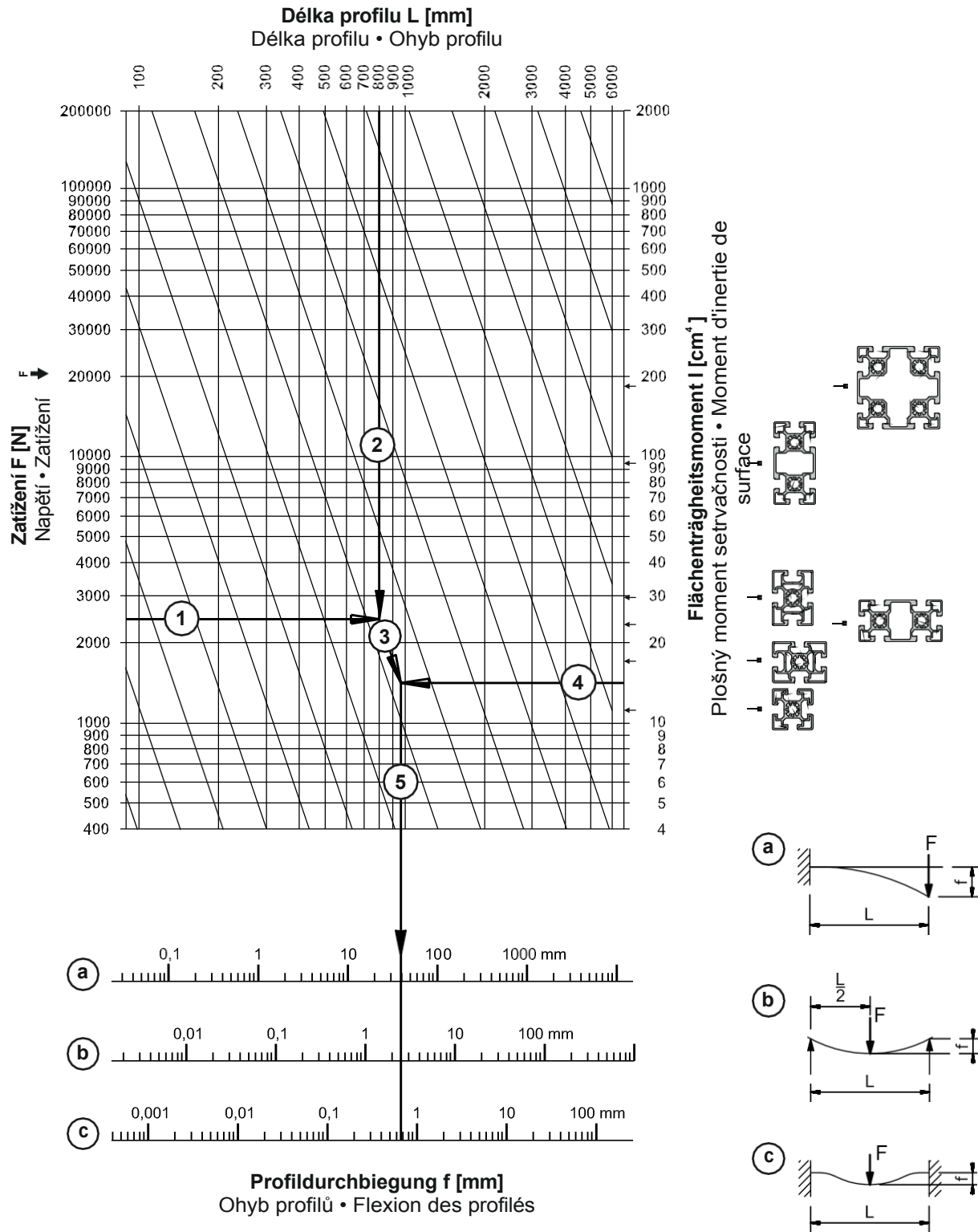

45x45 N-1,9

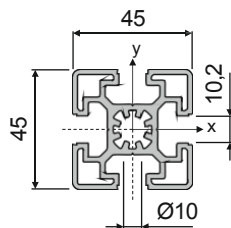
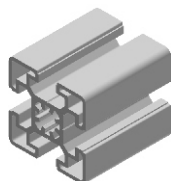

05.01498.00

$$\begin{aligned} M &= 1,88 \text{ kg/m} \\ I_x &= 12,95 \text{ cm}^4 \\ S_x &= 5,76 \text{ cm}^3 \\ I_y &= 12,95 \text{ cm}^4 \\ S_y &= 5,76 \text{ cm}^3 \end{aligned}$$

PE (m)
6 / 48 / 96 / 144

2

45x60 N-2,85

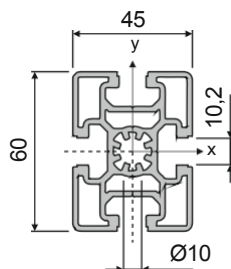
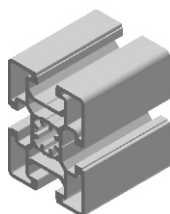

05.01499.00

$$\begin{aligned} M &= 2,85 \text{ kg/m} \\ I_x &= 29,72 \text{ cm}^4 \\ S_x &= 9,91 \text{ cm}^3 \\ I_y &= 17,63 \text{ cm}^4 \\ S_y &= 7,84 \text{ cm}^3 \end{aligned}$$

PE (m)
6 / 24 / 48 / 72

45x90 N-3,4

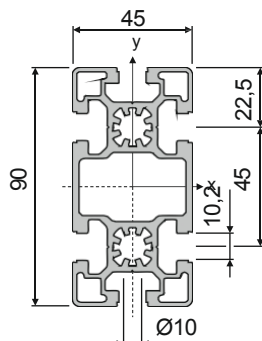
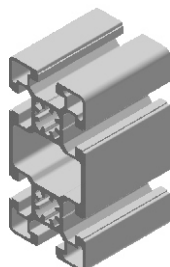

05.01013.00

$$\begin{aligned} M &= 3,40 \text{ kg/m} \\ I_x &= 94,84 \text{ cm}^4 \\ W_x &= 21,08 \text{ cm}^3 \\ I_y &= 24,90 \text{ cm}^4 \\ S_y &= 11,07 \text{ cm}^3 \end{aligned}$$

PE (m)
6 / 24 / 48 / 72

90x90 N

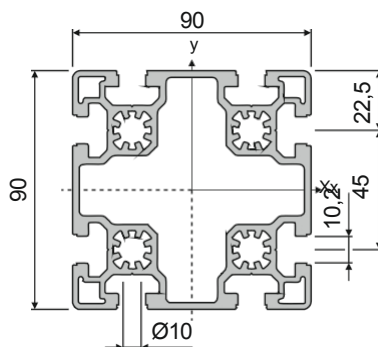
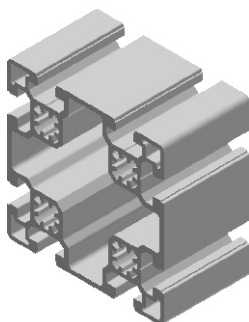

05.01014.00

$$\begin{aligned} M &= 5,68 \text{ kg/m} \\ I_x &= 190,13 \text{ cm}^4 \\ S_x &= 38,28 \text{ cm}^3 \\ I_y &= 190,13 \text{ cm}^4 \\ S_y &= 38,28 \text{ cm}^3 \end{aligned}$$

PE (m)
6 / 24 / 48 / 72

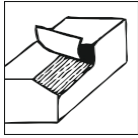

PROFILBEARBEITUNG

PROFILOVÉ DOKONČOVÁNÍ

USINAGE DE PROFILES

	1x	1x	2x	4x	
	05.xxxxx.09				
M12x60		05.xxxxx.10			M16x115 05.xxxxx.12
M12x60		M12x60 05.xxxxx.11			M16x115 M16x115 05.xxxxx.13

	↓	↓	↓ ↓	↓ ↓	
VSI 9,5	05.xxxxx.15 ■ 3,21				AGV 05.xxxxx.35 ■ 3,04
VSI 9,5		VSI 9,5 05.xxxxx.16			AGV AGV 05.xxxxx.36
BV17	05.xxxxx.25 ■ 3.06				UNI 05.xxxxx.40 ■ 3.11
BV17		BV17 05.xxxxx.26			UNI UNI 05.xxxxx.41
GV16	05.xxxxx.30 ■ 3.02				VSA 20 05.xxxxx.45 ■ 3,20
GV16		GV16 05.xxxxx.31			VSA 20 VSA 20 05.xxxxx.46

Technické změny vyhrazeny

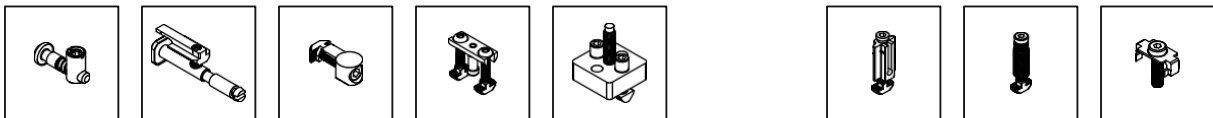

Konkávnost

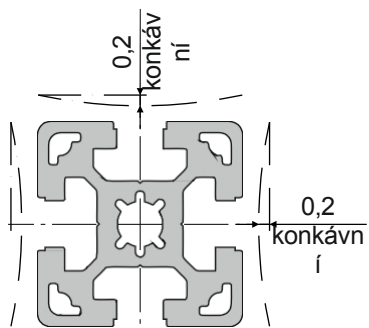

Mat ice

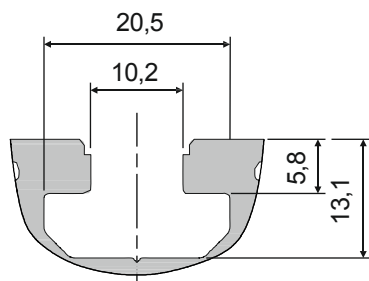

Kernloch

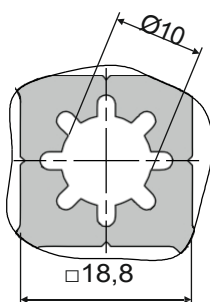

Vnější hrana

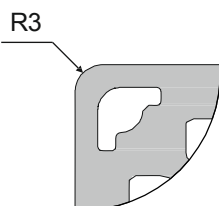

45x45MS-2.1



■ 2,67

60x60S



■ 2,68

45x45S



■ 2,67

60x90S



■ 2,68

45x60S



■ 2,67

90x90S



■ 2,68

45x90S



■ 2,67

90x180S



■ 2,69

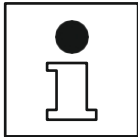

Průhyb profilů
 Průhyb profilů Průhyb
 profilů

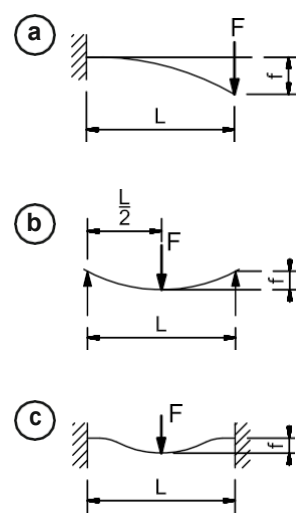
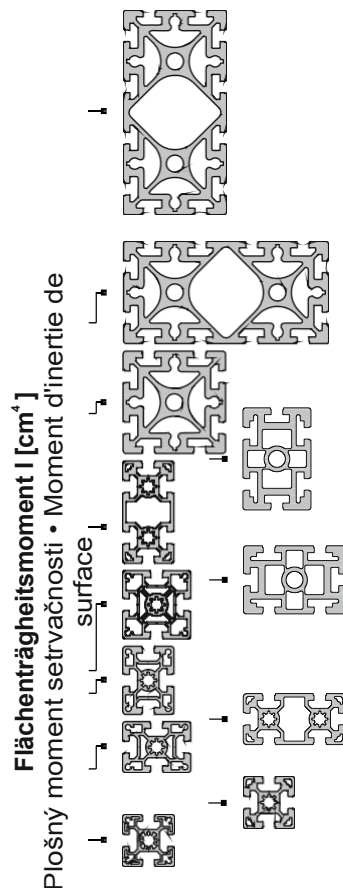
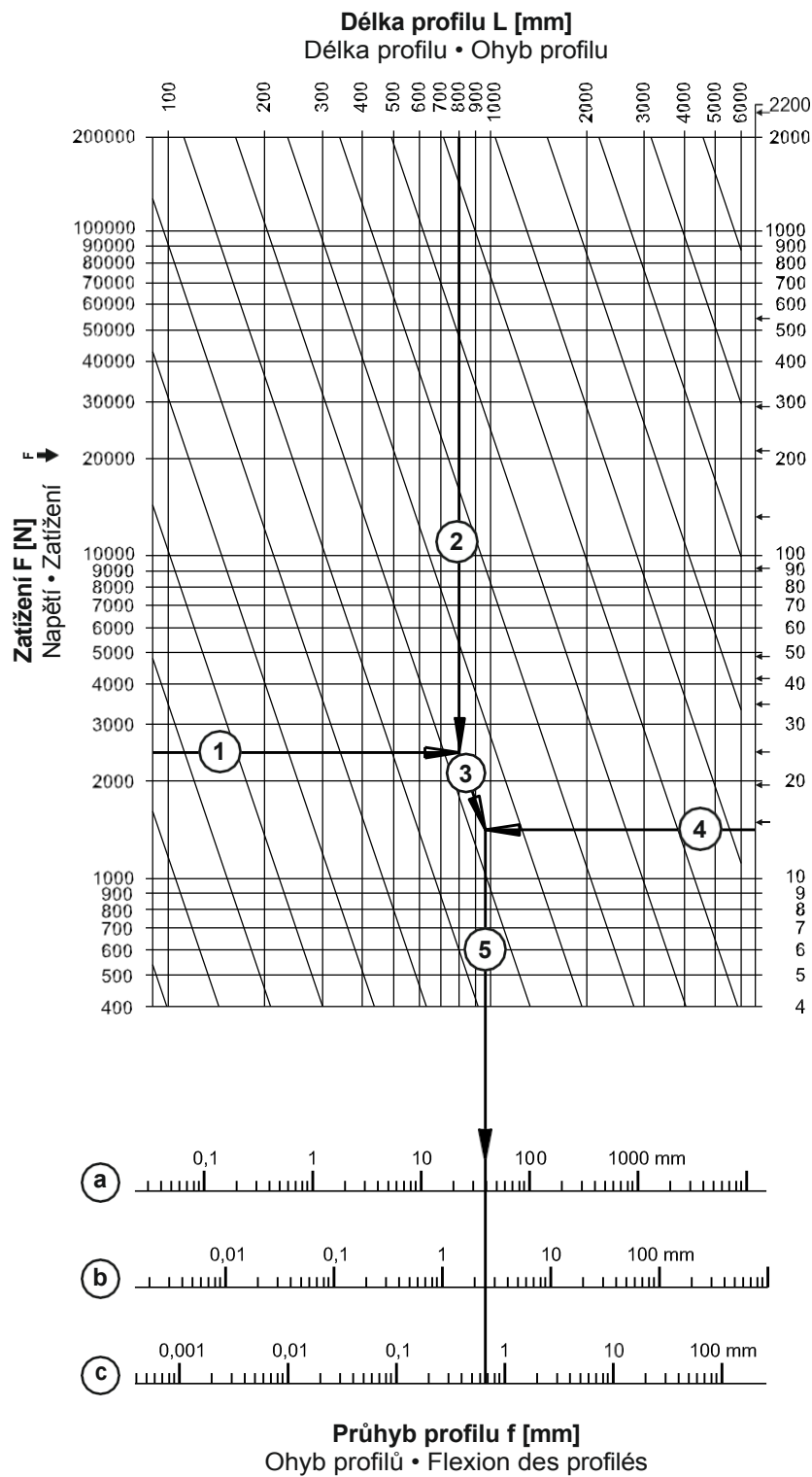

Technické změny vyznačeny

PROFILY
ALU-PROFIL
 PROFILY



45x45 MS-2.1

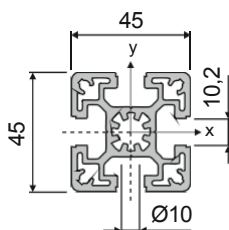
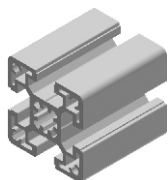

05.01009.00

$M = 2,10 \text{ kg/m}$ I
 $x = 15,56 \text{ cm}^4$ $W = 6,92 \text{ cm}^3$
 $I_y = 15,56 \text{ cm}^4$ $\check{S} = 6,92 \text{ cm}^3$

PE (m)
 6 / 48 / 96 / 144



45x45 S

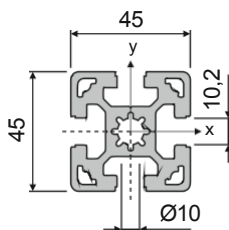
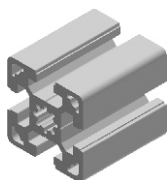

05.01010.00

$M = 2,62 \text{ kg/m}$
 $I_x = 18,95 \text{ cm}^4$
 $\check{S}_x = 8,42 \text{ cm}^3$
 $I_y = 18,95 \text{ cm}^4$ $\check{S} = 8,42 \text{ cm}^3$

PE (m)
 6 / 48 / 96 / 144

45x60 S

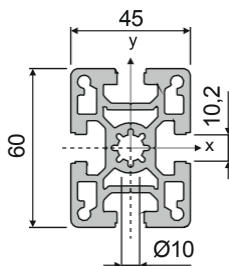
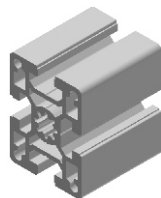

05.01011.00

$M = 3,30 \text{ kg/m}$
 $I_x = 41,06 \text{ cm}^4$
 $\check{S}_x = 13,69 \text{ cm}^3$
 $I_y = 23,68 \text{ cm}^4$ $\check{S} = 10,52 \text{ cm}^3$

PE (m)
 6 / 24 / 48 / 72

45x90 S

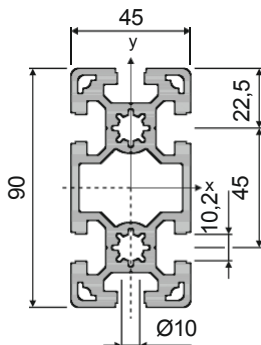
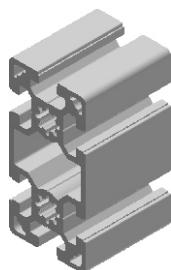

05.01015.00

$M = 4,40 \text{ kg/m}$
 $I_x = 134,96 \text{ cm}^4$
 $W_x = 29,99 \text{ cm}^3$
 $I_y = 33,27 \text{ cm}^4$ $\check{S} = 14,79 \text{ cm}^3$

PE (m)
 6 / 24 / 48 / 72

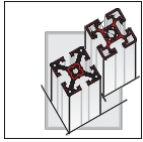

ALU-PROFILE PROFILY PROFILY

45

10

60x60 S

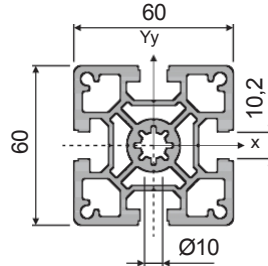
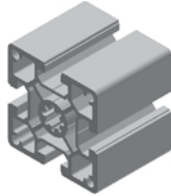

05.01017.00

M = 3,82 kg/m
 $I_x = 48,36 \text{ cm}^4$
 $S_x = 16,12 \text{ cm}^3$
 $I_y = 48,36 \text{ cm}^4$
 $S_y = 16,12 \text{ cm}^3$

PE (m)
 6 / 18 / 36 / 54

60x90 S

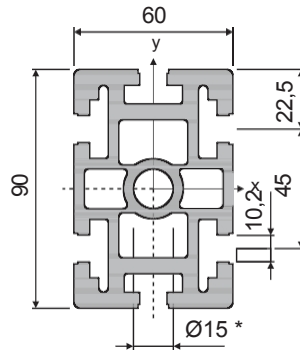
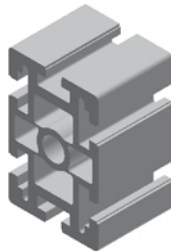

05.01016.00

M = 6,87 kg/m
 $I_x = 215,97 \text{ cm}^4$
 $W_x = 47,99 \text{ cm}^3$
 $I_y = 91,41 \text{ cm}^4$
 $S_y = 30,47 \text{ cm}^3$

PE (m)
 6 / 18 / 36 / 54

*
Závít M16 v jádrovém otvoru Ø15 provádějte pouze pomocí nástroje pro tváření závitů!
 Závít M16 v jádrovém otvoru o průměru 15 vyrábějte pouze pomocí nástroje pro tváření závitů! Produire le filetage M16 avec trou de noyau de Ø15 uniquement avec un outil de taraudage !

90x90 S

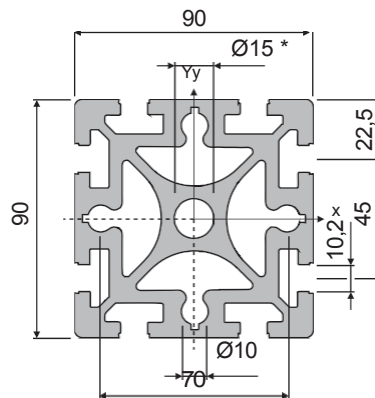
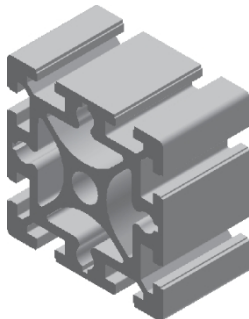

05.01018.00

M = 10,43 kg/m
 $I_x = 298,12 \text{ cm}^4$
 $S_x = 66,25 \text{ cm}^3$
 $I_y = 298,12 \text{ cm}^4$
 $S_y = 66,25 \text{ cm}^3$

PE (m)
 6 / 24 / 48 / 72

*
Závít M16 v jádrovém otvoru Ø15 provádějte pouze pomocí závitového nástroje!
 Závít M16 v jádrovém otvoru o průměru 15 vyrábějte pouze pomocí nástroje pro tváření závitů! Produire le filetage M16 avec trou de noyau de Ø15 uniquement avec un outil de taraudage !

PROFILY
ALU-PROFIL
 PROFILY

45

10

90x180 S

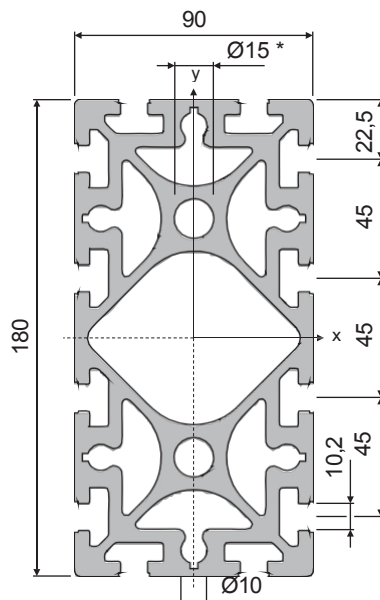
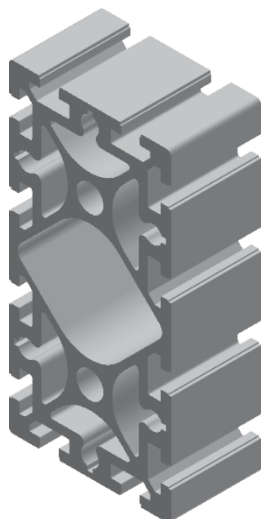

05.01019.00

M = 17,57 kg/m
 I_{x-x} = 2180,42 cm⁴
 S_{x-x} = 242,27 cm³
 I_{y-y} = 557,95 cm⁴
 S_{y-y} = 123,99 cm³

PE (m)
 6 / 12 / 24 / 36

*

Závit M16 v jádrovém otvoru Ø15 provádějte pouze pomocí závitového nástroje!

Závit M16 v jádrovém otvoru o průměru 15 vyrábějte pouze pomocí nástroje pro tváření závitů! Produire le filetage M16 avec trou de noyau de Ø15 uniquement avec un outil de taraudage !

2

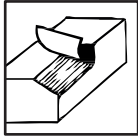















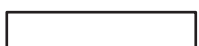

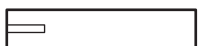
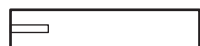













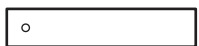
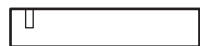



PROFILBEARBEITUNG

ÚPRAVA PROFILŮ

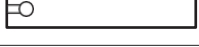
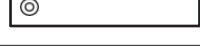

USINAGE DE PROFILES



 1x	 1x	 2x	 1x	 1x	 1x	 2x
45x45	45x60	45x90	60x60	60x90	90x90	90x180
		 05.xxxxx.09				
M12x60					 05.xxxxx.12	
M12x60					 05.xxxxx.13	

						
45x45	45x60	45x90	60x60	60x90	90x90	90x180
VSI 9,5					 05.xxxxx.15 ■ 3,21	
VSI 9,5					 05.xxxxx.16 ■ 3,04	
BV17					 05.xxxxx.25 ■ 3,06	
BV17					 05.xxxxx.26 ■ 3,11	
GV16					 05.xxxxx.30 ■ 3,02	
GV16					 05.xxxxx.31 ■ 3,20	

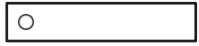
45x90

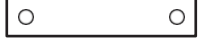
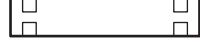
BV17V		05.xxxxx.85 ■ 3,06	UNI		05.xxxxx.43 ■ 3,11
BV17V		05.xxxxx.86	UNI		05.xxxxx.44

Technické změny vyhrazeny

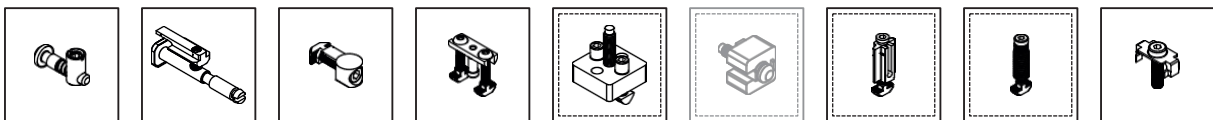

PROFILY
PROFILY
PROFILE ALU-

50

10

Konkávita

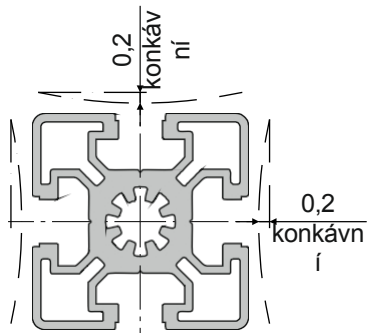

50x50L



■ 2,75

50x100L

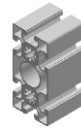

■ 2,75

100x100L

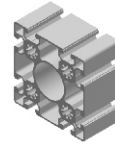

■ 2,75

Ořech

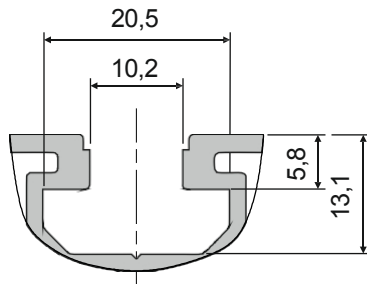

Kernloch

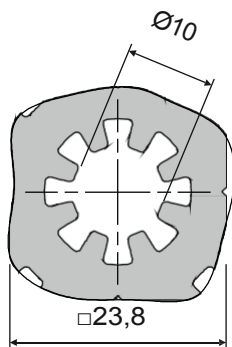

Vnější hrana

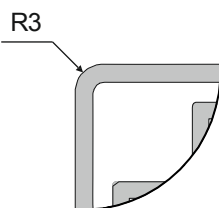

2

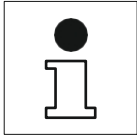

Průhyb profilů
 Průhyb profilů Průhyb
 profilů

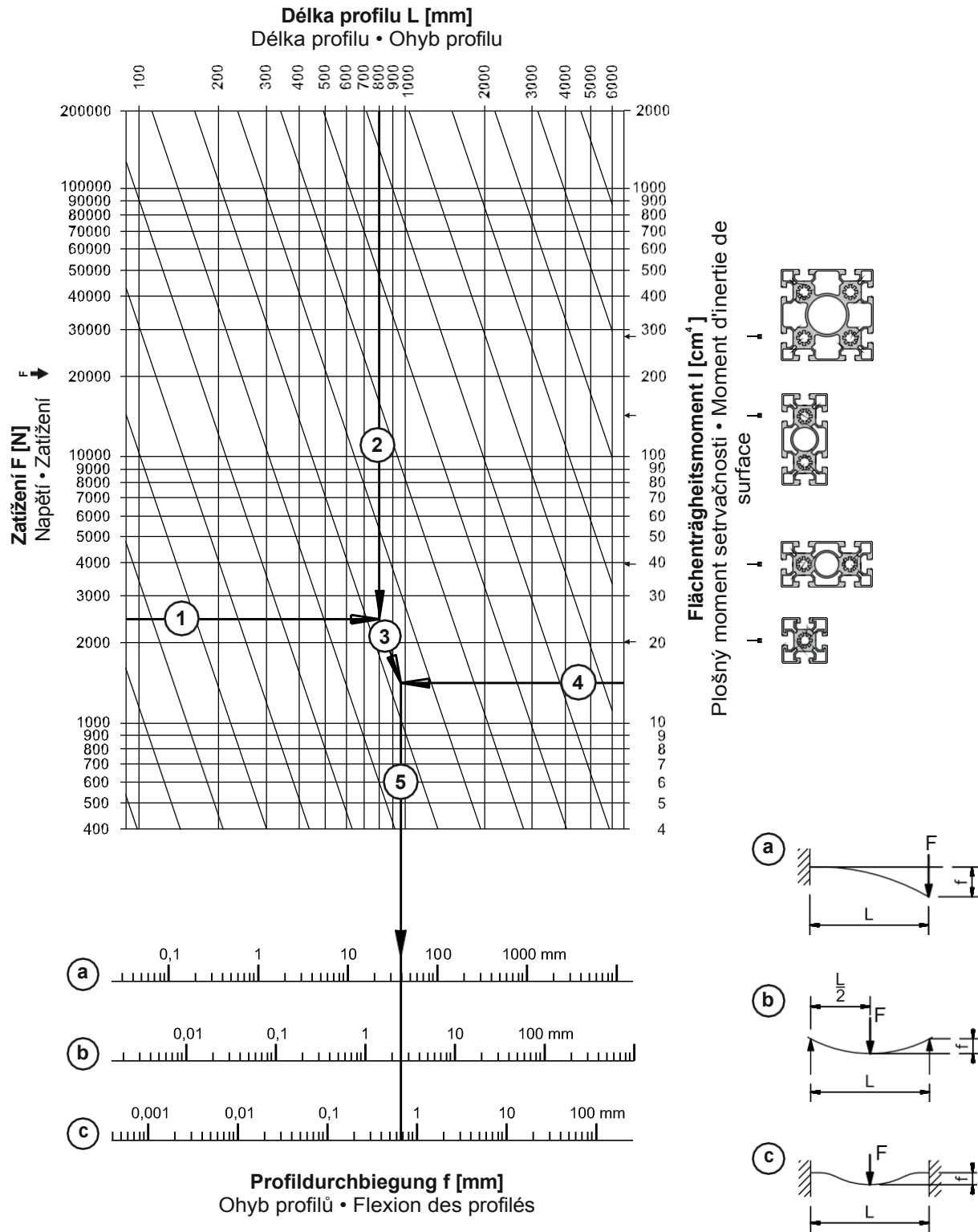

Technické změny vyznačeny



50x50 L

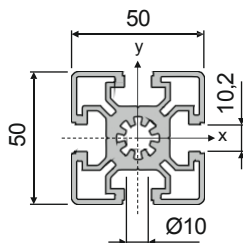
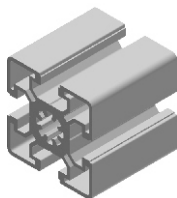

05.01700.00

M = 2,52 kg/m
I_x = 19,17 cm⁴
S_x = 7,67 cm³
I_y = 19,17 cm⁴
S_y = 7,67 cm³

PE (m)
6 / 48 / 96 / 144

2

50x100 L

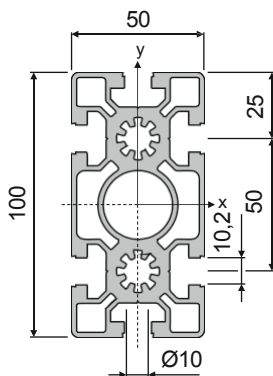
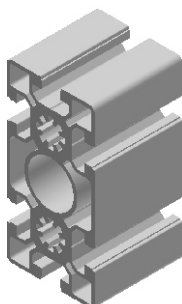

05.01702.00

M = 5,00 kg/m
I_x = 166,60 cm⁴
S_x = 33,32 cm³
I_y = 39,75 cm⁴
S_y = 15,90 cm³

PE (m)
6 / 24 / 48 / 72

100 x 100 L

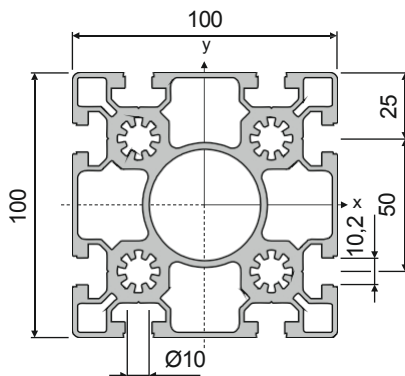
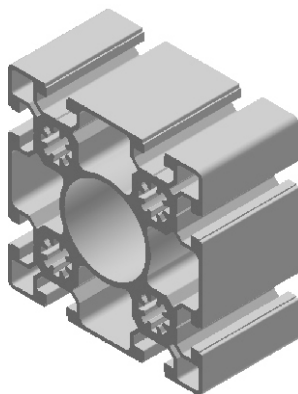

05.01703.00

M = 8,28 kg/m
I_x = 293,00 cm⁴
S_x = 58,60 cm³
I_y = 293,00 cm⁴
S_y = 58,60 cm³

PE (m)
6 / 24 / 48 / 72

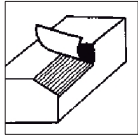

PROFILBEARBEITUNG

PROFILOVÉ DOKONČOVÁNÍ

USINAGE DE PROFILES



	1x	2x	4x	
	50x50	50x100	100x100	
				05.xxxxx.09
M12x60				05.xxxxx.10
M12x60				05.xxxxx.11
M16x115				05.xxxxx.12
M16x115				05.xxxxx.13

	50x50	50x100	100x100	
VSI 9,5				05.xxxxx.15 ■ 3,21
VSI 9,5				05.xxxxx.16
BV17				05.xxxxx.25 ■ 3,06
BV17				05.xxxxx.26
GV16				05.xxxxx.30 ■ 3,02
GV16				05.xxxxx.31
AGV				05.xxxxx.35 ■ 3,04
AGV				05.xxxxx.36
UNI				05.xxxxx.40 ■ 3,11
UNI				05.xxxxx.41
VSA 20				05.xxxxx.45 ■ 3,20
VSA 20				05.xxxxx.46

	50x100			
BV17V				05.xxxxx.85 ■ 3,06
BV17V				05.xxxxx.86
UNI				05.xxxxx.43 ■ 3,11
UNI				05.xxxxx.44

Technické změny vyhrazeny

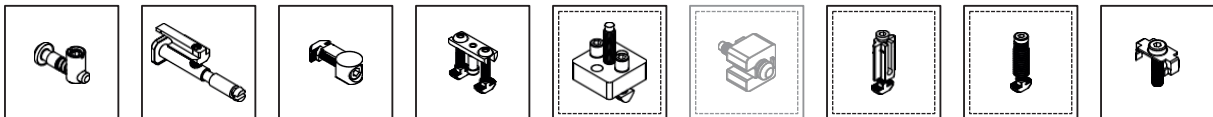

PROFILY
PROFILY
PROFILE ALU-

S
50

10

Konkávita

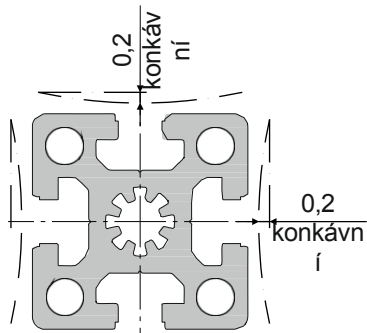

50x50S



■ 2,77

50x100S



■ 2,77

100x100S

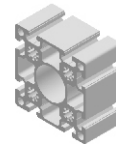

■ 2,77

Matice

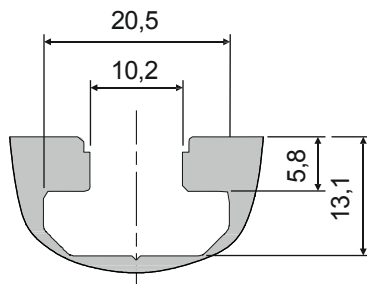

Kernloch

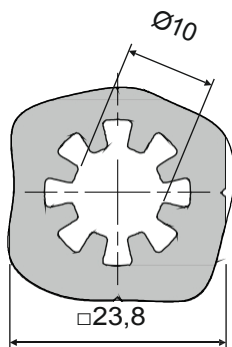

Vnější hrana

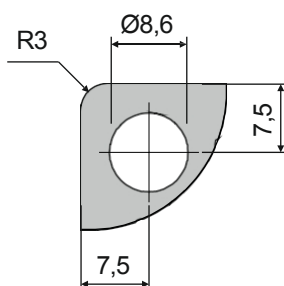

2

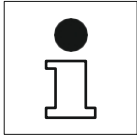

Průhyb profilů
 Průhyb profilů Flexion
 des profilés

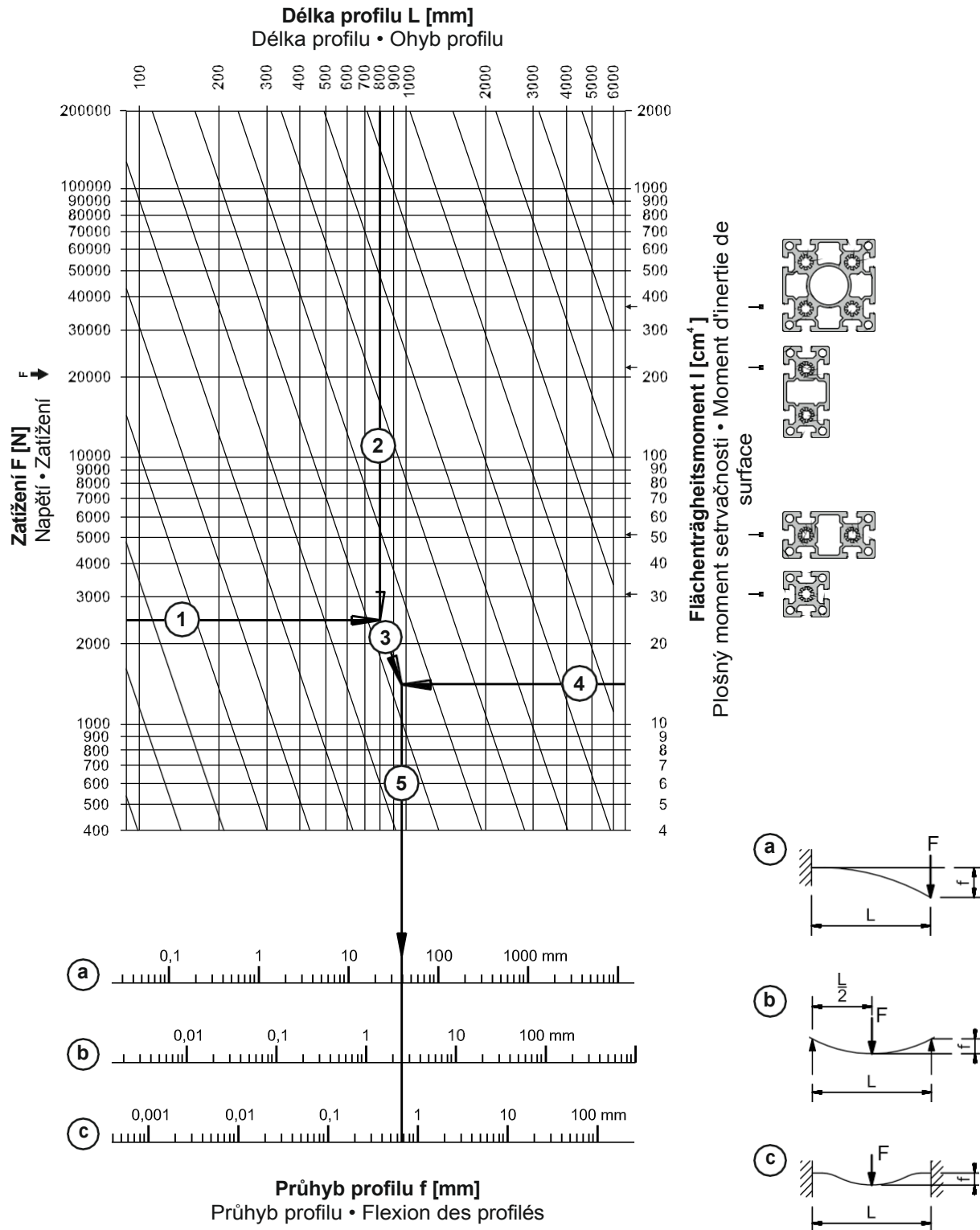

Technické změny vyznačeny

50x50 S

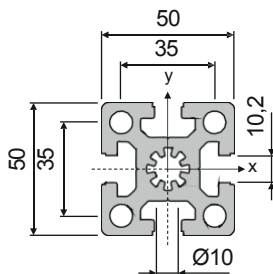
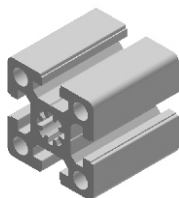

05.01705.00

$$\begin{aligned}
 &= 3,54 \text{ kg/m} \\
 I_x &= 29,62 \text{ cm}^4 \\
 \dot{S}_x &= 11,85 \text{ cm}^3 \\
 I_y &= 29,62 \text{ cm}^4 \\
 \dot{S}_y &= 11,85 \text{ cm}^3
 \end{aligned}$$

PE (m)
6 / 48 / 96 / 144

2

50x100 S

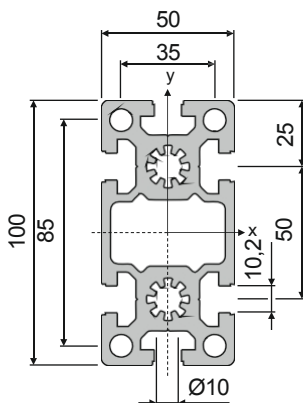
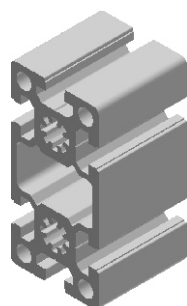

05.01706.00

$$\begin{aligned}
 M &= 5,92 \text{ kg/m} \\
 I_x &= 219,85 \text{ cm}^4 \\
 \dot{S}_x &= 43,97 \text{ cm}^3 \\
 I_y &= 52,23 \text{ cm}^4 \\
 \dot{S}_y &= 20,89 \text{ cm}^3
 \end{aligned}$$

PE (m)
6 / 24 / 48 / 72

100x100 S

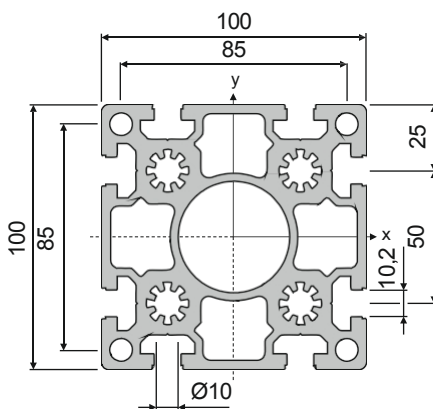
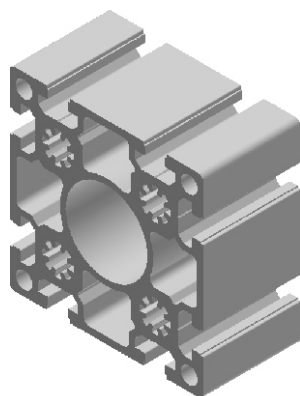

05.01707.00

$$\begin{aligned}
 M &= 10,45 \text{ kg/m} \\
 I_x &= 383,00 \text{ cm}^4 \\
 \dot{S}_x &= 76,60 \text{ cm}^3 \\
 I_y &= 383,00 \text{ cm}^4 \\
 \dot{S}_y &= 76,60 \text{ cm}^3
 \end{aligned}$$

PE (m)
6 / 24 / 48 / 72

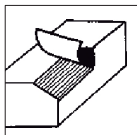

PROFILBEARBEITUNG

PROFILOVÉ DOKONČOVÁNÍ

USINAGE DE PROFILES

50x50	50x100	100x100		
			05.xxxxx.09	
M12x60			05.xxxxx.10	
M12x60		M12x60	05.xxxxx.11	
				05.xxxxx.12
				05.xxxxx.13

50x50	50x100	100x100		
VSI 9,5			05.xxxxx.15 ■ 3,21	AGV
VSI 9,5		VSI 9,5	05.xxxxx.16	AGV
BV17			05.xxxxx.25 ■ 3,06	UNI
BV17		BV17	05.xxxxx.26	UNI
GV16			05.xxxxx.30 ■ 3,02	VSA 20
GV16		GV16	05.xxxxx.31	VSA 20
				05.xxxxx.35 ■ 3,04
				05.xxxxx.36
				05.xxxxx.40 ■ 3,11
				05.xxxxx.41
				05.xxxxx.45 ■ 3,20
				05.xxxxx.46







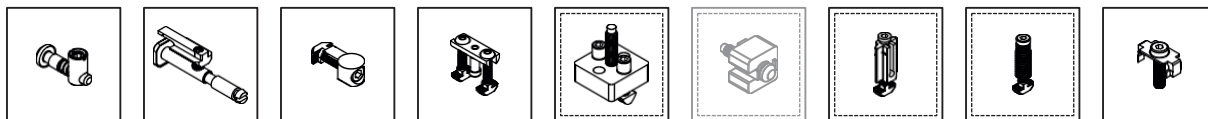















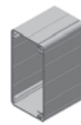

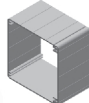



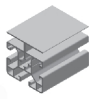

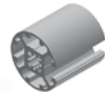
50x100

BV17V		05.xxxxx.85 ■ 3,06	UNI		05.xxxxx.43 ■ 3,11
BV17V		05.xxxxx.86	UNI		05.xxxxx.44

Technické změny vyhrazeny



DOPLŇKOVÉ PROFILY
DOPLŇKOVÉ PROFILY
DOPLŇKOVÉ PROFILY

					
■ 2,81	■ 2,81	■ 2,81	■ 2,82	■ 2,82	■ 2,82
					
➔ ■ 8,10	➔ ■ 8,36	➔ ■ 8,15	➔ ■ 8,29	➔ ■ 8,29	➔ ■ 8,30
					
➔ ■ 9,06	➔ ■ 9,06	➔ ■ 9,06	➔ ■ 9,07	➔ ■ 9,07	➔ ■ 9,07
					
➔ ■ 11,05	➔ ■ 11,05	➔ ■ 11,05	➔ ■ 11,16	➔ ■ 11,18	
					
➔ ■ 12,02	➔ ■ 12,08	➔ ■ 12,08	➔ ■ 12,08	➔ ■ 12,09	➔ ■ 7,07
					
➔ ■ 13,02	➔ ■ 13,17	➔ ■ 13,17	➔ ■ 13,19		

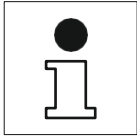

Průhyb profilů
 Průhyb profilů Průhyb
 profilů

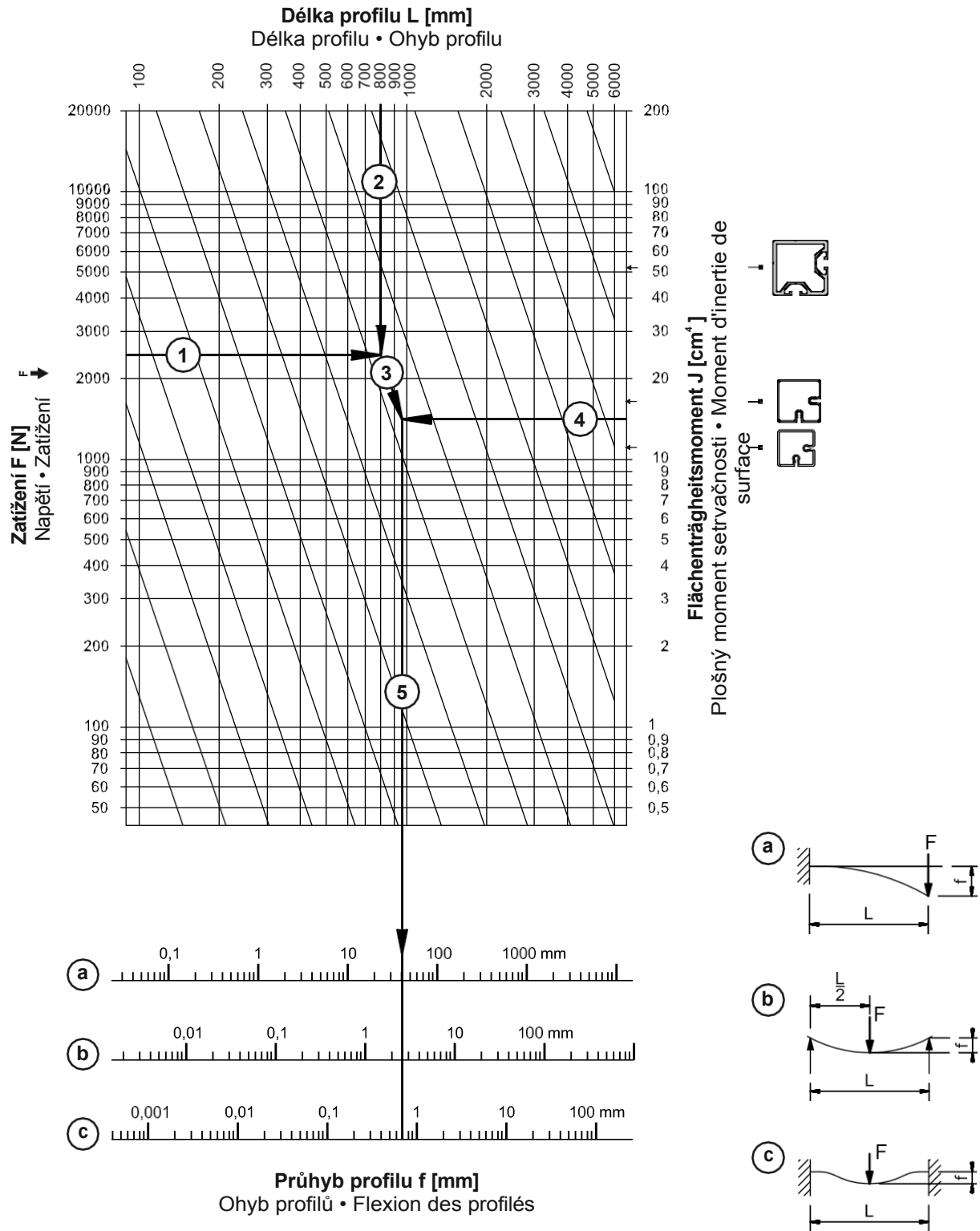

Technické změny vyznačeny

TELESKOPIKÉ PROFILY
TELESCOPE PROFILES
PROFILES TELESCOPIQUES



40/45

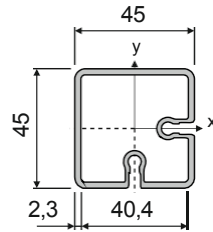
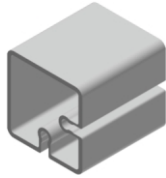

05.01946.00

M = 1,20 kg/m
I_x = 11,80 cm⁴
W_x = 5,24 cm³
I_y = 11,80 cm⁴
W_y = 5,24 cm³

PE (m)
6 / 48 / 96

M8 L=65mm



05.01971.00

M8 x 14



05.01436.00



05.01652.00

45/50

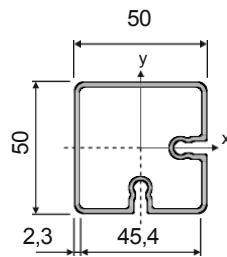
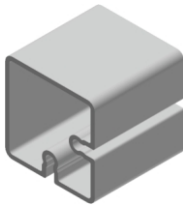

05.01947

M = 1,40 kg/m
I_x = 17,07 cm⁴
W_x = 7,59 cm³
I_y = 17,07 cm⁴
W_y = 7,59 cm³

PE (m)
6 / 48 / 96

M8 L=65 mm



05.01971.00

M8 x 14



05.01436.00



05.01064,00

60x60

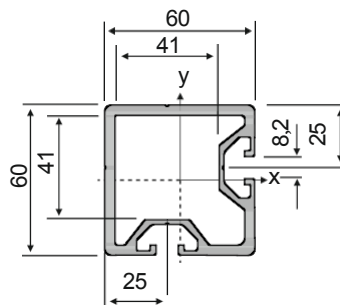

05.01951.00

M = 3,02 kg/m
I_x = 52,04 cm⁴
W_x = 17,28 cm³
I_y = 53,06 cm⁴
W_y = 17,63 cm³

PE (m)
6